

DIPLOMA EXAMINATION IN ENGINEERING/TECHNOLOGY/  
MANAGEMENT/COMMERCIAL PRACTICE — OCTOBER, 2018

**THEORY OF STRUCTURES - II**

[Time : 3 hours

(Maximum marks : 100)

PART — A

(Maximum marks : 10)

Marks

I Answer *all* questions in one or two sentences. Each question carries 2 marks.

1. Define slenderness ratio of a column.
2. Show the core area of rectangular and circular sections.
3. Define a fixed beam.
4. Define elastic curve of a loaded beam.
5. Define carry over factor in moment distribution method.

(5×2 = 10)

PART — B

(Maximum marks : 30)

II Answer any *five* of the following questions. Each question carries 6 marks.

1. Calculate the safe compressive load on a hollow cast iron column, one end rigidly fixed and the other end hinged of 150mm external diameter, 100mm internal diameter and 10m length. Use Euler's formula with a factor of safety of 5. Take E as 95 GPa.
2. Find the crippling load by Rankine's formula for a hollow cylindrical steel column of 38mm external diameter and 2.5mm thick. Take the length of the column as 2.3m and hinged at both ends. Take E = 205 GPa, Rankine's constant as 335 MPa and  $\frac{1}{7500}$ .
3. State the conditions for the stability of a dam.
4. For a solid circular section of diameter 'd' show that the limiting value of eccentricity for no tension to develop in the section is  $\frac{d}{8}$ .

5. A 250mm long cantilever of rectangular section 40mm wide and 30mm deep carries a uniformly distributed load per unit length. Calculate the value of 'w', if the maximum deflection not to exceed 0.5mm. Take  $E = 70 \text{ GPa}$ .
6. A cantilever beam 120mm wide and 150mm deep is 1.8m long. Determine the slope and deflection at the free end of the beam, when it carries a point load of 20kN at its free end. Take 'E' as 200 GPa.
7. Explain Hardy cross method of moment distribution for the analysis of indeterminate structures. (5×6 = 30)

## PART — C

(Maximum marks : 60)

(Answer *one* full question from each unit. Each full question carries 15 marks.)

## UNIT — I

- III (a) A 'T' section  $150\text{mm} \times 120\text{mm} \times 20\text{mm}$  is used as a strut of 4m long with hinged at its both ends. Calculate the Euler's crippling load, if Young's modulus for the material be 200GPa. Take Moment of inertia of the beam section,  $I_{xx} = 6.09 \times 10^6 \text{mm}^4$  and  $I_{yy} = 5.069 \times 10^6 \text{mm}^4$ . 8
- (b) The truss ABC shown in figure has a span of 5 metres. It is carrying a load of 10 kN. Find the forces in the members AB, AC and BC.

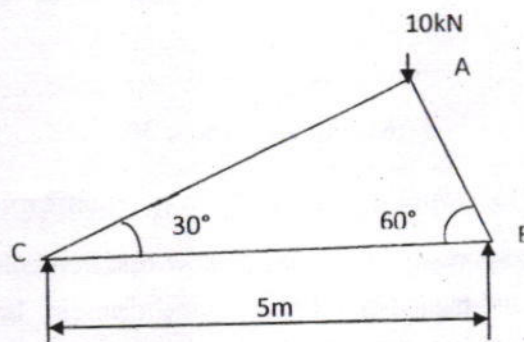

7

OR

- IV (a) A built up column consisting of  $150\text{mm} \times 100\text{mm}$  R.S.J with  $120\text{mm} \times 12\text{mm}$  plate riveted to each flange. Calculate the safe load, the column can carry, if it is 4m long having one end fixed and other end hinged with a factor of safety 3.5. Take the properties of the built up column as Area =  $5047\text{mm}^2$ ,  $I_{xx} = 27.32 \times 10^6 \text{mm}^4$  and  $I_{yy} = 4.404 \times 10^6 \text{mm}^4$ . Assume crushing strength of the column 315MPa and Rankine's constant (a) =  $\frac{1}{7500}$ . 9
- (b) What is meant by equivalent length of column? Write the equivalent length for various end conditions. 6

## UNIT — II

- V (a) A hollow circular column having external diameter of 350mm and wall thickness 25mm. It carries a vertical load of 80 kN at the outer edge of the column. Calculate the maximum and minimum intensities of the stresses at the section. 8
- (b) A beam of 6m span has its ends built in and carries a uniformly distributed load of 3kN/m. Find the maximum bending moment and deflection. Given  $EI = 20 \times 10^8 \text{kN/mm}^2$ . 7

OR

- VI (a) A short column 100 mm  $\times$  100mm is subjected to an eccentric load of 80 kN at an eccentricity of 40mm in the plane bisecting the two opposite faces. Find the maximum and minimum intensities of stresses at the base section. 8
- (b) Explain the following terms related to retaining wall.  
(i) Weep holes      (ii) Active earth pressure      (iii) Passive earth pressure 7

## UNIT — III

- VII (a) A timber beam of rectangular section 120mm wide and 240mm deep is simply supported over a span of 4m. If the deflection of the beam is not to exceed 4mm, find the maximum value of central point load the beam can support. Take young's modulus,  $E = 110 \text{kN/mm}^2$ . Also calculate the slope at ends when this load is carried. 8
- (b) Apply Mohr's theorems to determine the slopes and deflections of a cantilever with point load at free end having length 'L' and point load 'W'. 7

OR

- VIII (a) A simply supported beam of span 9m is loaded with two point loads of 40kN and 30kN at a distance of 2m and 6m respectively from left support. Using Macaulay's method, calculate deflection under the loads. 8
- (b) A cantilever beam 3m span carries a point load of 25 kN at the free end. Using moment area method, find the slope and deflection at the free end. Take  $E = 200 \text{kN/mm}^2$  and moment of inertia of the section is  $360 \times 10^6 \text{mm}^4$ . 7

## UNIT — IV

- IX (a) A two span continuous beam has two equal spans with a point load 'W' at the middle of each span. Find the fixed end moment at the middle support and sketch the BM diagram and shear force diagram. Take EI as constant. 10
- (b) Explain how to find distribution factor for the members OA, OB, OC meet at a rigid point 'O'. The ends 'A&B' are fixed and 'C' is hinged. 5

OR

- X A continuous beam ABC, 8m long consists of two spans  $AB = 3\text{m}$  and  $BC = 5\text{m}$ . The span AB carries a UDL of 50kN/m and BC carries a UDL of 30kN/m. Find the support moment at B and the reactions at the supports. Sketch the S.F and B.M diagrams. Take EI as constant. 15

18



**GOVT. OF KERALA**  
**DEPARTMENT OF TECHNICAL EDUCATION**  
**OFFICE OF THE CONTROLLER OF TECHNICAL EXAMINATIONS**  
**THIRUVANANTHAPURAM**

DIPLOMA EXAMINATION IN ENGINEERING / TECHNOLOGY / MANAGEMENT

CORRECTION NOTE (scheme)

Revision & Sub code: 4014C15  
Subject: Theory of structures - II  
Verified by: PAUL

Q. No: III a)

$I_{yy}$  given  $5.069 \times 10^6$

but in substitution the value is taken as  $5.69 \times 10^6$

The result will be changed  $P_e = \underline{624 \text{ KN}}$

VIII a) As per syllabus deflection of beams limited for symmetric loads only. But in given question loading is not symmetric

SCORING INDICATORS

CODE: (15) 4014

VERSION: A

Qn.No		Split score	Total score
-------	--	-------------	-------------

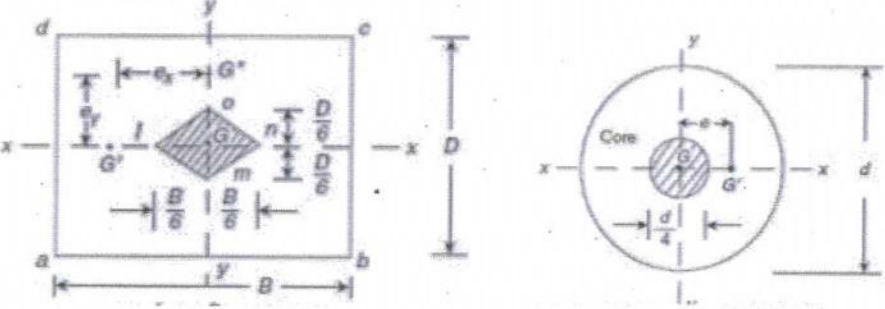
Qn.No	PART-A	Split score	Total score
I. 1	Slenderness ratio ( $\lambda$ ) is the ratio of the effective length of a column ( $L_e$ ) and the least radius of gyration ( $r$ ) about the axis under consideration.	2	
2	core area of rectangular and circular sections		
		2	
3	A beam that is supported at both <del>free</del> ends and is restrained against rotation and vertical movement. Also known as built-in beam; encasté beam		
4	The deformed axis of the beam from its neutral axis is called its elastic curve.	2	
5	<u>Carry over factor</u> : It is the ratio of moment transferred to the far end and moment applied to the other end of the beam.	2	
II)	<u>SOLUTION</u>	2	10
1	<p>External diam, <math>D = 150\text{mm} = 0.15\text{m}</math>                      Internal diam, <math>d = 100\text{mm} = 0.1\text{m}</math>                      Length of column, <math>l = 10\text{m}</math>                      Factor of safety = 5.  <math>E = 95\text{GN/m}^2</math></p> $L_e = \frac{l}{\sqrt{2}} = \frac{10}{\sqrt{2}} = 7.07\text{m}$ $P_e = \frac{\pi r^2 EI}{le^2}$ $P_e = \frac{\pi^2 \times 95 \times 10^9 \times \pi / 64 (0.15^4 - 0.1^4) \times 10^{-3}}{(7.07)^2}$ $= 374\text{kN}$ <p>safe load <math>= P_{e/FOS} = 374/5 = \underline{74.8\text{kN}}</math></p>	1 2 2 1	6

3

2

**SOLUTION**

External dia m ,D = 38mm  
 Thickness,d = 2.5cm  
 Internal diam = 38-(2x2.5) = 33mm  
 Yield strength( $\sigma$ ) = 335N/mm<sup>2</sup>

$$\text{Rankines constnt(a)} = \frac{1}{7500}$$

$$I = \frac{\pi}{64} (D^4 - d^4) = \frac{\pi}{64} (38^4 - 33^4) = 14.05 \times 10^3 \pi \text{ mm}^4$$

$$A = \frac{\pi}{4} (D^2 - d^2) = 88.75 \pi \text{ mm}^2$$

$$K = \sqrt{\frac{I}{A}} = \sqrt{\frac{14.05 \times 10^3}{88.75}} = 12.6 \text{ mm}$$

$$\text{Rankines crippling load} = \frac{\sigma_{cs} \cdot A}{1 + a \left(\frac{Le}{k}\right)^2} = \frac{335 \times 88.75 \pi}{1 + \frac{1}{7500} \{(2.3 \times 10^3) / 12.6\}^2}$$

$$= \underline{17.16 \text{ kN}}$$

1  
1  
1  
2  
1

6

3

1. Against Overturning of dam about the toe
2. Against Sliding – shear failure of gravity dam
3. Against Compression – by crushing of the gravity dam
4. Against Tension – by development of tensile forces which results in the crack in gravity dam.

**Overturning of Gravity Dam:**

The ratio of the resisting moments about toe to the overturning moments about toe is called the factor of safety against overturning. Its value generally varies between 2 and 3.

2

Factor of safety against overturning is given by

$$\text{FOS} = \frac{\text{sum of overturning moments}}{\text{sum of resisting moments}}$$

**Against Sliding of Gravity Dam:**

Factor of safety against sliding can be given based on

- Frictional resistance
- Frictional resistance and shear strength of the dam

factor of safety based on frictional resistance:

$$\text{FOS against sliding} = \text{FOS} = \frac{\mu \Sigma V}{\Sigma H}$$

2

**gravity Dam Failure due to Tension Cracks**

The dam loses contact with the bottom foundation due to this crack and becomes ineffective and fails. Hence, the effective width B of the dam base will be reduced. This will increase pmax at the toe.

Hence, a tension crack by itself does not fail the structure, but it leads to the

4

failure of the structure by producing excessive compressive stresses.

For high gravity dams, certain amount of tension is permitted under severest loading conditions in order to achieve economy in design.

**Gravity Dam Failure due to Compression**

A gravity dam may fail by the failure of its material, i.e. the compressive stresses produced may exceed the allowable stresses, and the dam material may get crushed.

1

1

6

4

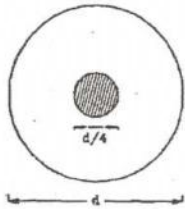

$$A = \frac{\pi d^2}{4}, I = \frac{\pi d^4}{64}$$

$$Z = \frac{I}{Y} = \frac{\pi d^4 \times 2}{64 \times d} = \frac{\pi d^3}{32}$$

For no tension in the base

$$e = \frac{Z}{A} = \frac{\pi d^3 \times 4}{32 \times \pi \times d} = \frac{d}{8}$$

2

2

2

6

5

Solution

Length,  $L = 250 \text{ mm} = 0.25 \text{ m}$ .

Width,  $b = 40 \text{ mm} = 0.04 \text{ m}$

Depth,  $d = 30 \text{ mm} = 0.03 \text{ m}$

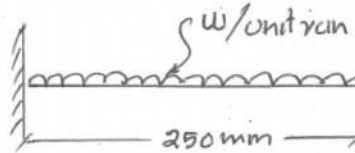

M.I.,  $I = \frac{bd^3}{12} = \frac{0.04 \times 0.03^3}{12} = 9 \times 10^{-8} \text{ mm}^4$

$E = 70 \text{ GN/m}^2$

Maximum deflection,  $y_{\text{max}} = 0.5 \text{ mm} = 0.0005 \text{ m}$ .

Maximum deflection,  $y_{\text{max}} = \frac{wl^4}{8EI}$

$$0.0005 = \frac{w \times (0.25)^4}{8 \times 70 \times 10^9 \times 9 \times 10^{-8}} = 0.0005$$

$$w = \frac{0.0005 \times 8 \times 70 \times 10^9 \times 9 \times 10^{-8}}{(0.25)^4} = 6451 \text{ N/m}$$

$$w = 6.451 \text{ kN/m}$$

1

1

1

2

1

6

5

6

Solution:

$$b = 120 \text{ mm}, d = 150 \text{ mm}, l = 1.80 \text{ m}$$

$$E = 200 \text{ GPa} = 200 \times 10^3 \text{ N/mm}^2$$

$$I = \frac{bd^3}{12} = \frac{120 \times 150^3}{12} = 33.75 \times 10^6 \text{ mm}^4$$

$$\text{slope at the free end} = \frac{Wl^2}{2EI} = \frac{(20 \times 10^3) \times (1.8 \times 10^3)^2}{2 \times (200 \times 10^3) \times (33.75 \times 10^6)}$$

$$\theta_B = 0.0048 \text{ rad}$$

$$\text{Deflection} = y_B = \frac{Wl^3}{3EI} = \frac{20 \times 10^3 \times (1.8 \times 10^3)^3}{3 \times (200 \times 10^3) \times (33.75 \times 10^6)} = 5.76 \text{ mm}$$

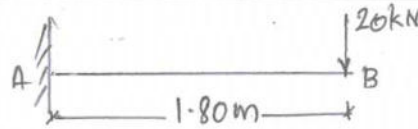

7

The moment distribution method for beams may be summarized as follows:

1. Determine the stiffness for each member.

For a member that is fixed at both ends, use equation

$$K_{AB} = 4EI/L$$

For a member that has a pin at one end, use equation

$$K_{AB} = 3EI/L$$

2. Determine the distribution factors for each member at each node based on relative stiffness of the members using equation

$$DF_{AB} = k_{AB} / \sum k_i$$

Use a distribution factor of zero for a fixed support and 1.0 for a pinned support with only one connected member.

3. Determine the fixed end moments for all members that have external loads applied between the end nodes

4. For each node in turn:

A. Determine the unbalanced moment on the node

B. Distribute the unbalanced moment to each member connected to the node in proportion to the distribution factors in the reverse direction of the unbalanced moment.

C. For each member that the moment has been distributed to, carry over some of the moment to the opposite end of the member according to equations.

For a member with a fixed end opposite (a regular locked node), carry over half of the moment that was applied by the distribution. For a member with a pinned end opposite (where there are no other members connected to that pin) do not carry over any moment.

5. Repeat the previous step for each node, multiple times as necessary until the carry over moments are a small fraction of the total moments at each member end

6. Sum all of the moments in each member end from all previous steps (including the original fixed end moments). This sum gives the total moment at each member end in the real system.

III  
(a)

PART-C

Solution

Given  $I_{xx} = 6.09 \times 10^6 \text{ mm}^4$  and  $I_{yy} = 5.069 \times 10^6 \text{ mm}^4$   
 Since  $I_{yy}$  is less than  $I_{xx}$ , the column will tend to buckle in  $yy$ -direction.

$\therefore I = I_{yy}$

$L_e = l = 4 \times 10^3 \text{ mm}$  (since both ends hinged)

$P_e = \frac{\pi^2 EI}{L_e^2} = \frac{\pi^2 \times (200 \times 10^3) \times (5.69 \times 10^6)}{(4 \times 10^3)^2}$

$P_e = 702 \times 10^3 \text{ N}$   
 $= \underline{\underline{702 \text{ kN}}}$

1  
1  
4  
2

8

III  
(b)

Solution

From geometry of the truss

Taking moments about C

$R_B \times 5 = 10 \times 3.75$   
 $R_B = 7.50 \text{ kN}$   
 $R_C = 10 - 7.5$   
 $= 2.50 \text{ kN}$

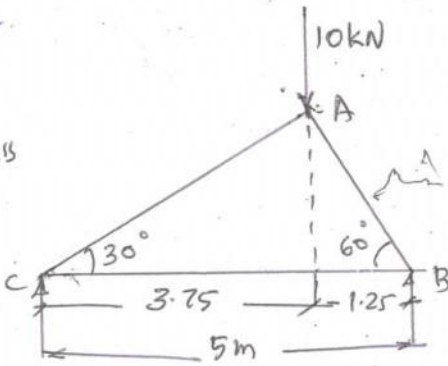

Consider joint c

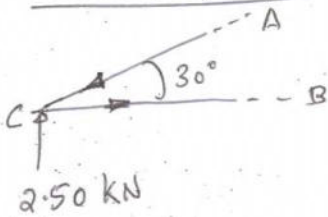

$P_{AC}$  and  $P_{BC}$

$P_{AC} \sin 30^\circ = 2.50$   
 $\therefore P_{AC} = \frac{2.50}{\sin 30} = \underline{\underline{5.0 \text{ kN (C)}}$

Consider joint B

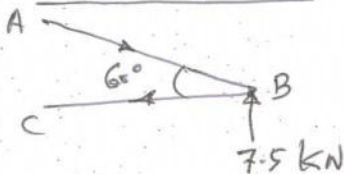

$P_{AC} \cos 30^\circ = P_{BC} = 5 \times 0.866$   
 $P_{BC} = \underline{\underline{4.33 \text{ kN (T)}}$

$P_{AB} \sin 60^\circ = 7.5$   
 $P_{AB} = \frac{7.5}{\sin 60} = \underline{\underline{8.66 \text{ kN (C)}}$

$P_{BC} = P_{AB} \cos 60^\circ$   
 $P_{BC} = 8.66 \times 0.50 = \underline{\underline{4.33 \text{ kN (T)}}$

1  
2  
1  
1  
1

7

IV  
(a)

Solution  
Since  $I_{yy}$  is less than  $I_{xx}$ , there for the column will tend to buckle in Y-Y direction.

$$I = I_{yy} = 4.404 \times 10^6 \text{ mm}^4$$

$$\text{Total area, } A = 5047 \text{ mm}^2$$

$$\text{Crushing strength, } \sigma = 315 \text{ MPa} = 315 \text{ N/mm}^2, a = \frac{1}{7500}$$

Column is fixed at one end and hinged at other end,  $L_e = \frac{L}{\sqrt{2}}$

$$L_e = \frac{L}{\sqrt{2}} = \frac{4 \times 10^3}{\sqrt{2}} = 2.83 \times 10^3 \text{ mm}$$

$$\therefore k = \sqrt{\frac{I}{A}} = \sqrt{\frac{4.404 \times 10^6}{5047}} = 29.5 \text{ mm}$$

$$\text{Rankines Crippling load} = \frac{\sigma_c \cdot A}{1 + a \left[ \frac{L_e}{k} \right]^2}$$

$$= \frac{315 \times 5047}{1 + \frac{1}{7500} \left[ \frac{2.83 \times 10^3}{29.5} \right]^2} = 714 \text{ kN}$$

$$\text{Safe load on the column} = \frac{\text{Crippling load}}{\text{FOS}} = \frac{714}{3.5} = \underline{\underline{204 \text{ kN}}}$$

The equivalent column length can be defined as the length of an equivalent pin-ended column having the same load-carrying capacity as the member under consideration.

(b)

End Condition

Relationship between the equivalent length and the actual length

1. Both Ends Hinged

$$L_e = L$$

2. One End Fixed,  
Other End Free

$$L_e = 2L$$

3. Both Ends Fixed

$$L_e = \frac{L}{2}$$

4. One End Fixed,  
Other End Hinged

$$L_e = \frac{L}{\sqrt{2}}$$

6

8

V

Solution

(a)

$D = 350 \text{ mm}$

$d = 350 - (2 \times 25) = 300 \text{ mm}$

$W = 80 \text{ kN}$

$e = \frac{350}{2} = 175 \text{ mm}$  ( $\because$  load is at outer edge)

$A = \frac{\pi}{4} (0.35^2 - 0.30^2) = 0.0255 \text{ m}^2$

$Z = \frac{\pi}{32} \left( \frac{D^4 - d^4}{D} \right) = \frac{\pi}{32} \left( \frac{0.35^4 - 0.30^4}{0.35} \right) = 0.001937 \text{ m}^3$

Direct stress,  $f_a = W/A = \frac{80}{0.0255} = 3137.255 \text{ kN/m}^2$

Bending stress,  $f_b = \frac{We}{Z} = \frac{80 \times 0.175}{0.001937} = 7227.672 \text{ kN/m}^2$

Maximum stress =  $f_a + f_b = 3137.255 + 7227.672$   
 $= \underline{\underline{10404.927 \text{ kN/m}^2}}$

Minimum stress =  $f_a - f_b = 3137.255 - 7227.672$   
 $= \underline{\underline{-4090.417 \text{ kN/m}^2}}$

1  
1  
2  
1  
1  
1

V

(b)

For simply supported conditions

Maximum BM =  $\frac{wl^2}{8} = \frac{3 \times 6^2}{8} = 13.5 \text{ kN}\cdot\text{m}$

By symmetry in loading

F.E.M at A = F.E.M at B

i.e.  $M_A = M_B = \frac{wl^2}{12}$   
 $= \frac{3 \times 6^2}{12} = 9 \text{ kN}\cdot\text{m}$

ii) maximum positive BM

$= 13.5 - 9 = 4.5 \text{ kN}\cdot\text{m}$

$R_A = R_B = \frac{3 \times 6}{2} = 9 \text{ kN}$

ii) maximum Deflection occurs at the mid span =  $\frac{wl^4}{384 EI}$

$y_{\text{max}} = \frac{3 \times 6^4 \times 1000^3}{384 \times 20 \times 10^8} = \underline{\underline{5.063 \text{ mm}}}$

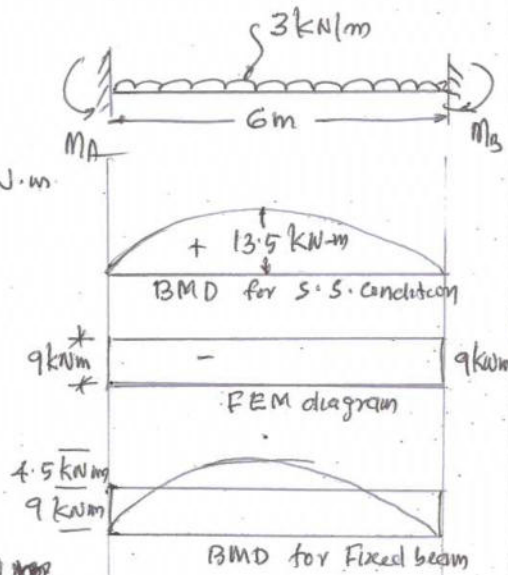

1  
1  
1  
2

8

67

VI	(a)	<p><u>Solution</u></p> <p>Given, <math>W = 80 \text{ kN}</math>  <math>e = 40 \text{ mm} = 0.04 \text{ m}</math>  <math>b = d = 100 \text{ mm} = 0.1 \text{ m}</math>  Area, <math>A = b \times d = 0.1 \times 0.1 = 0.01 \text{ m}^2</math>  <math>Z = \frac{1}{6} bd^2 = \frac{1}{6} \times 0.1 \times 0.1^2</math>  <math>Z = 0.1667 \times 10^{-3} \text{ m}^3</math>  Direct stress, <math>f_a = \frac{W}{A} = \frac{80}{0.01} = 8000 \text{ kN/m}^2</math>  Bending stress, <math>f_b = \frac{W \cdot e}{Z} = \frac{80 \times 0.04}{0.1667 \times 10^{-3}} = 19196.16 \text{ kN/m}^2</math>  <math>f_a = 8 \text{ N/mm}^2, f_b = 19.196 \text{ N/mm}^2</math>  <math>\therefore f_{\text{max}} = 8 + 19.196 = 27.196 \text{ N/mm}^2 \text{ (Compression)}</math>  <math>f_{\text{min}} = 8 - 19.196 = -11.196 \text{ N/mm}^2 \text{ (Tensile)}</math></p>	<p>1 1 1 1 2 2</p>	8
VI	(b)	<p><u>1. Weep Holes</u>  provided in earth retaining structures like retaining walls, underpasses, wing walls and other below ground drainage structures.  Weep Hole is provided in these structures to relieve hydrostatic pressure or water pressure on the walls.  Reducing the water pressure on the walls will reduce the structural design demand of the water or earth resisting wall by reducing its thickness as well as reinforcement requirements.</p> <p><u>2. Active earth pressure</u>  The minimum value of lateral earth pressure exerted by soil on a structure and the wall moves away from the backfill, occurring when the soil is allowed to yield sufficiently to cause its internal shearing resistance along a potential failure surface to be completely mobilized.</p> <p><u>3. Passive earth pressure</u>  When the wall moves towards the back fill, there is an increase in the pressure on the wall and this increase continues until a maximum value has reached after which there is no increase in the pressure and the value will become constant. This kind of pressure is known as passive earth pressure.</p>	<p>2 2 1/2 2 1/2</p>	7

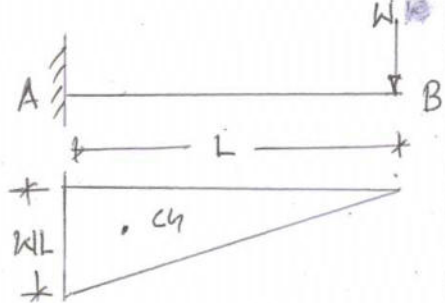
<p>VII (a)</p>	<p><u>Solution</u> Let the central point load be 'W'</p> $I = \frac{bd^3}{12} = \frac{1}{12} \times 120 \times 240^3 = 138.24 \times 10^6 \text{ mm}^4$ $E = 110 \text{ kN/mm}^2, y_{\text{max}} = 4 \text{ mm}$ $y_{\text{max}} = \frac{WL^3}{48EI}$ $4 = \frac{W \times 4^3 \times 10^9}{48 \times 110 \times 138.24 \times 10^6}$ $W = \underline{\underline{49.6 \text{ kN}}}$ <p>Slope at the ends <math>\theta_A = -\frac{WL^2}{16EI} = \frac{49.6 \times 4^2 \times 1000^2}{16 \times 110 \times 138.24 \times 10^6}</math></p> $\theta_A = \theta_B = -\underline{\underline{0.003 \text{ radians}}}$ $\theta_B = +\underline{\underline{0.003 \text{ radians}}}$	<p>1</p> <p>2</p> <p>1</p> <p>2</p> <p>2</p>	<p>8</p>
<p>VII (b)</p>	<p>Consider a cantilever beam AB of length 'L' fixed at A carrying a point load 'W' at the free end.</p>  <p>1. Mohr's Theorem I</p> $\theta_B = \frac{\text{Area of Bm diagram}}{EI}$ $\text{Area, } A = WL \times \frac{L}{2} = \frac{WL^2}{2}$ $\theta_B = \frac{WL^2}{2EI}$ <p>2. Mohr's Theorem - II</p> <p>Deflection at B with respect to A</p> $y_B = \frac{A \cdot \bar{x}}{EI}$ $\bar{x} = \frac{2}{3}L$ $\therefore y_B = \frac{WL^2}{2} \times \frac{2}{3}L \times \frac{1}{EI} = \underline{\underline{\frac{WL^3}{3EI}}}$	<p>1,</p> <p>2</p> <p>1</p> <p>1</p> <p>2</p>	<p>7</p>

VIII (a)

Solution

Taking moments about 'B'

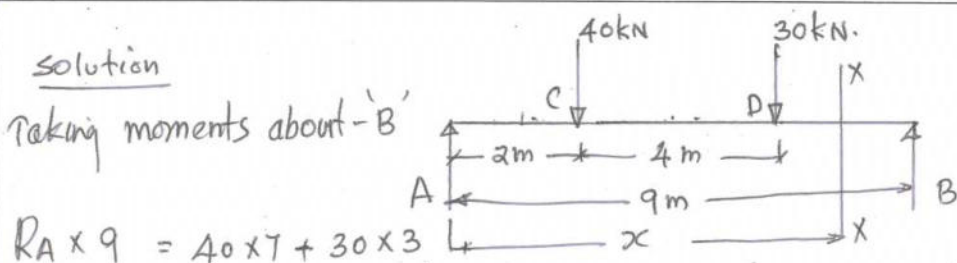

$$R_A \times 9 = 40 \times 7 + 30 \times 3$$

$$R_A = \frac{370}{9} = 41.11 \text{ kN}, \quad R_B = 70 - 41.11 = 28.89 \text{ kN}$$

Consider a section XX at a distance  $x$  from 'A'.

$$M_x = 41.11x - 40(x-2) - 30(x-6)$$

$$\therefore EI \frac{d^2y}{dx^2} = 41.11x - 40(x-2) - 30(x-6)$$

$$EI \frac{dy}{dx} = \frac{41.11x^2}{2} + c_1 - \frac{40}{2}(x-2)^2 - \frac{30}{2}(x-6)^2$$

$$EI y = \frac{41.11x^3}{6} + c_1x + c_2 - \frac{40}{6}(x-2)^3 - \frac{30}{6}(x-6)^3$$

At  $x=0, y=0$ , Hence  $c_2=0$ At  $x=L, y=0$ , substitute again in deflection eqn.

$$0 = \frac{41.11}{6}(9)^3 + c_1 \times 9 - 9 - \frac{40}{6}(9-2)^3 - \frac{30}{6}(9-6)^3$$

$$c_1 = -285.9$$

Substitute the value of  $c_1$  in slope eqn.

$$EI \frac{dy}{dx} = \frac{41.11x^2}{2} - 285.90 - 20(x-2)^2 - 15(x-6)^2$$

$$\text{and } EI y = \frac{41.11x^3}{6} - 285.90x - \frac{40}{6}(x-2)^3 - \frac{30}{6}(x-6)^3$$

Deflection Under loadDeflection under 40 kN load, substitute  $x=2$ 

$$y_C = \frac{1}{EI} \left[ \frac{41.11 \times 2^3}{6} - 285.90 \times 2 \right] = \underline{\underline{-1.615 \text{ mm}}}$$

Deflection under 30 kN load, substitute  $x=6$ .

$$y_D = \frac{1}{EI} \left[ \frac{41.11 \times 6^3}{6} - 285.90 \times 6 - \frac{40}{6}(6-2)^3 \right]$$

$$y_D = \underline{\underline{2.06 \text{ mm}}}$$

VIII  
(b)Solution

$$\text{Maximum BM} = 25 \times 3 \\ = 75 \text{ kNm}$$

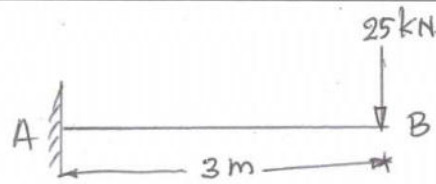

Area of BM diagram

$$A = \frac{1}{3} \times 3 \times 75 \\ = 112.5 \text{ kNm}^2$$

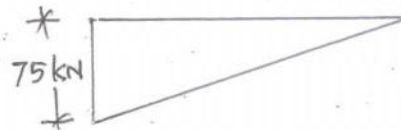
C.G of BM diagram from B =  $\frac{2}{3} \times 3 = 2 \text{ m}$ 

$$\text{slope at B} = \theta_B = \frac{\text{Area of BM diagram}}{EI}$$

$$= \frac{112.5 \times 10^6}{200 \times 360 \times 10^6} = \underline{\underline{0.00156 \text{ radians}}}$$

Deflection at 'B' with respect to 'A'

$$= \frac{\text{Moment of Area of BM diagram about A}}{EI}$$

$$= \frac{112.5 \times 2 \times 10^9}{200 \times 360 \times 10^6} = \underline{\underline{3.125 \text{ mm}}}$$

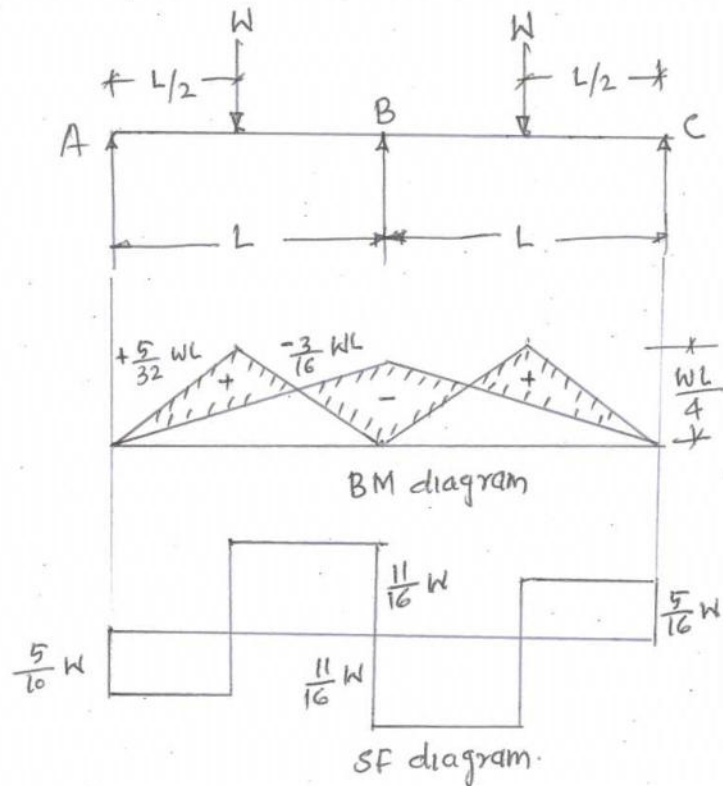
IX  
(a)

(2)

Free BM diagrams

$$\text{BM under load } W = \frac{W}{2} \times \frac{L}{2} = \frac{WL}{4}$$

$$\therefore \text{Area, } A_1 = A_2 = \frac{1}{2} \times L \times \frac{WL}{4} = \frac{WL^2}{8}$$

$$\bar{x}_1 = \bar{x}_2 = \frac{L}{2}$$

Applying clapeyron's theorem

$$M_A L_1 + 2M_B(L_1 + L_2) + M_C L_2 = - \left[ \frac{6A_1 \bar{x}_1}{L_1} + \frac{6A_2 \bar{x}_2}{L_2} \right]$$

Since the support A and C are simply supported and  $L_1 = L_2$ ;  $M_A = M_C = 0$

$$\therefore 0 + 2M_B(2L) + 0 + \frac{6}{L} \times \frac{WL^2}{8} \times \frac{L}{2} + \frac{6}{L} \times \frac{WL^2}{8} \times \frac{L}{2} = 0$$

$$4M_B L = -\frac{3}{4} \frac{WL^3}{L}$$

$$\therefore M_B = \frac{3}{16} WL \text{ (hogging)}$$

By super imposing

$$M_D = M_E = \frac{WL}{4} - \frac{1}{2} \left[ \frac{3}{16} WL \right] = \frac{+5}{32} WL$$

$$M_B = -\frac{3}{16} WL$$

$$M_D = +\frac{5}{32} WL$$

Taking moments about B for span BC

$$R_C \times L = W \frac{L}{2} - \frac{3}{16} WL$$

$$\therefore R_C = \frac{5}{16} W$$

Taking moments about B for span AB

$$R_A \times L = W \frac{L}{2} - \frac{3}{16} WL$$

$$\therefore R_A = \frac{5}{16} W$$

$$R_A + R_B + R_C = 2W$$

$$\therefore R_B = 2W - \frac{5}{16} W - \frac{5}{16} W$$

$$R_B = \frac{11}{8} W$$

$$R_A = R_C = \frac{5}{16} W$$

$$R_B = \frac{11}{8} W$$

1

1

1

10

IX  
(b)Solution

Let the length and Moment of inertia of the members be

$$OA = L_1 \text{ and } I_1$$

$$OB = L_2 \text{ and } I_2$$

$$OC = L_3 \text{ and } I_3$$

Let  $E =$  young's Modulus of the members

Let a clockwise moment  $M$  be applied at 'O', therefore the joint 'O' will undergo deformation as shown in the fig. The applied moment 'M' will be distributed among all the connecting members at the joint in proportion to their stiffness. Due to the rigidity of the joint all the members will be rotated through the same angle. Let  $M_1, M_2$  and  $M_3$  be the BM carried by each member

$$M_1 = \frac{4EI_1\theta_1}{L_1} = k_1\theta \quad \because \theta_1 = \theta_2 = \theta_3$$

$$M_2 = \frac{4EI_2\theta_2}{L_2} = k_2\theta$$

$$M_3 = \frac{4EI_3\theta_3}{L_3} = k_3\theta$$

Total stiffness of the members =  $\Sigma k = k_1 + k_2 + k_3$

Total moment applied at the joint =  $M = \Sigma k\theta$

$$\therefore \frac{M_1}{M} = \frac{k_1}{\Sigma k} \text{ or } M_1 = M \cdot \frac{k_1}{\Sigma k}$$

$\frac{k_1}{\Sigma k}$  is called Distribution factor for the member 'OA'

Similarly distribution factors for OB and OC are

$$\frac{k_2}{\Sigma k}, \frac{k_3}{\Sigma k}$$

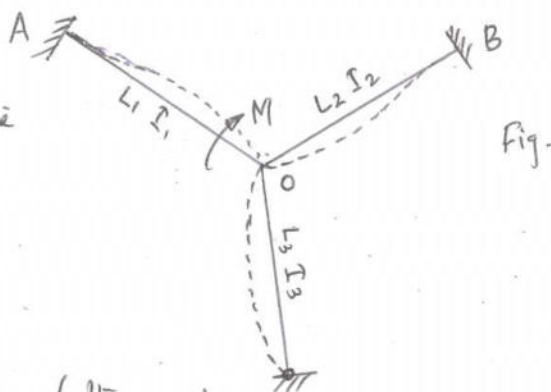

Fig.

1

1

1

2

5

x

Solution

$L_1 = 3\text{ m} , L_2 = 5\text{ m}$

$W_1 = 50\text{ kN/m} \quad W_2 = 30\text{ kN/m}$

For AB

Max free BM =  $\frac{W_1 L_1^2}{8} = \frac{50 \times 3^2}{8} = 56.25\text{ kN}\cdot\text{m}$

Area  $A_1 = \frac{2}{3} \times 56.25 \times 3 = 112.5\text{ kN}\cdot\text{m}^2$

$\bar{x}_1 = \frac{3}{2} = 1.5\text{ m}$

For BC

Max. free BM =  $\frac{W_2 L_2^2}{8} = \frac{30 \times 5^2}{8} = 93.75\text{ kN}\cdot\text{m}$

$A_2 = \frac{2}{3} \times 93.75 \times 5 = 312.5\text{ kN}\cdot\text{m}^2$

$\bar{x}_2 = \frac{5}{2} = 2.5\text{ m}$

Applying theorem of three moments to spans AB and BC.

$M_A L_1 + 2M_B (L_1 + L_2) + M_C L_2 + \frac{6A_1 \bar{x}_1}{L_1} + \frac{6A_2 \bar{x}_2}{L_2} = 0$

$M_A = M_B = 0$

$\therefore 0 + 2M_B (3+5) + 0 + \frac{6}{3} \times 112.5 \times 1.5 + \frac{6}{5} \times 312.5 \times 2.5 = 0$

$16M_B = -337.5 - 937.5 = -1275$

$\therefore M_B = \frac{-1275}{16} = -79.6875\text{ kN}\cdot\text{m}$  (Hogging moment)

For support Reactions

Taking moments about B for ABC and BC

$R_A \times 3 - 50 \times 3 \times \frac{3}{2} + 79.6875 = 0$

$\therefore R_A = 48.438\text{ kN}$

$R_C \times 5 - 30 \times 5 \times 2.5 + 79.6875 = 0$

$R_C = 59.06\text{ kN}$

$\therefore R_B = 300 - (48.438 + 59.063) = 192.5\text{ kN}$

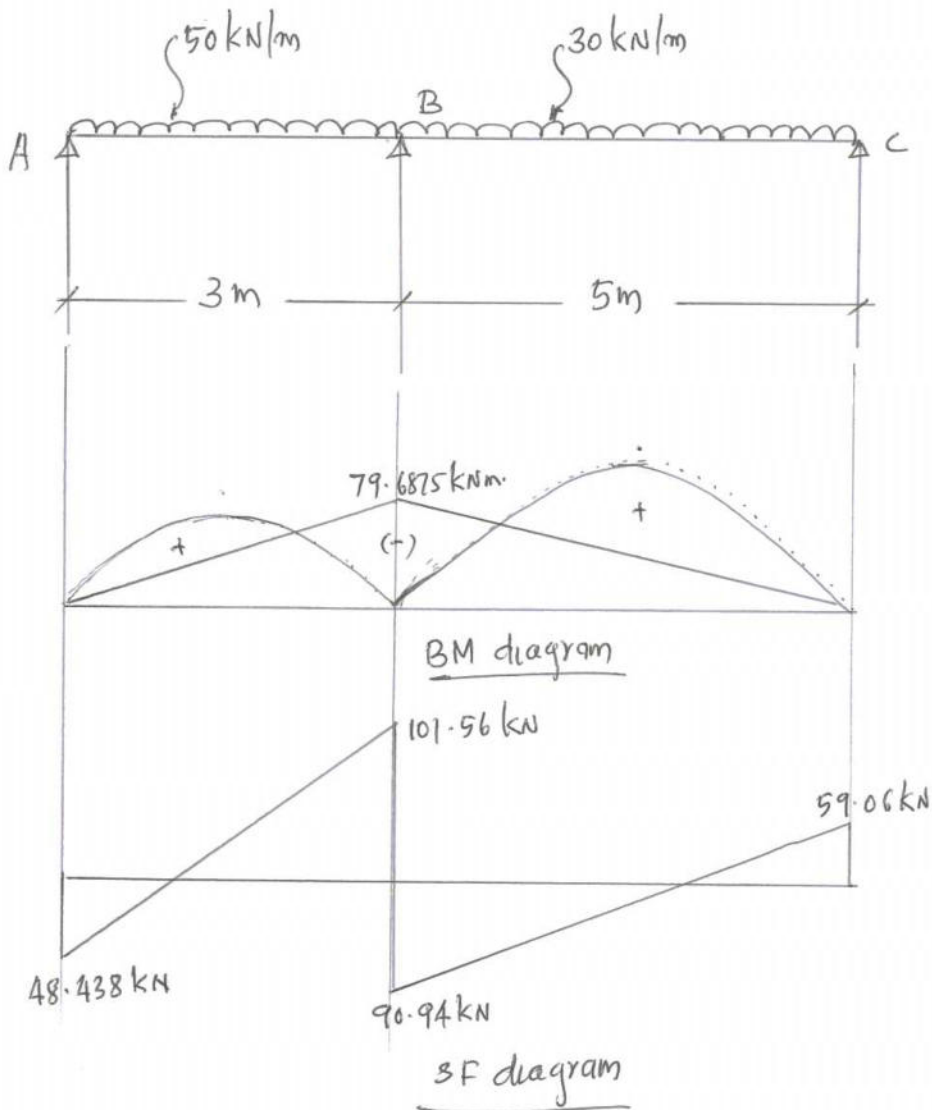

2

2

15

$$M_B = 79.6875 \text{ kNm}$$

$$R_A = 48.438 \text{ kN}$$

$$R_B = 90.94 \text{ kN}$$

$$R_C = 59.06 \text{ kN}$$