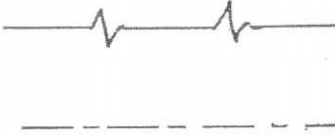
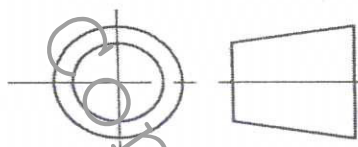
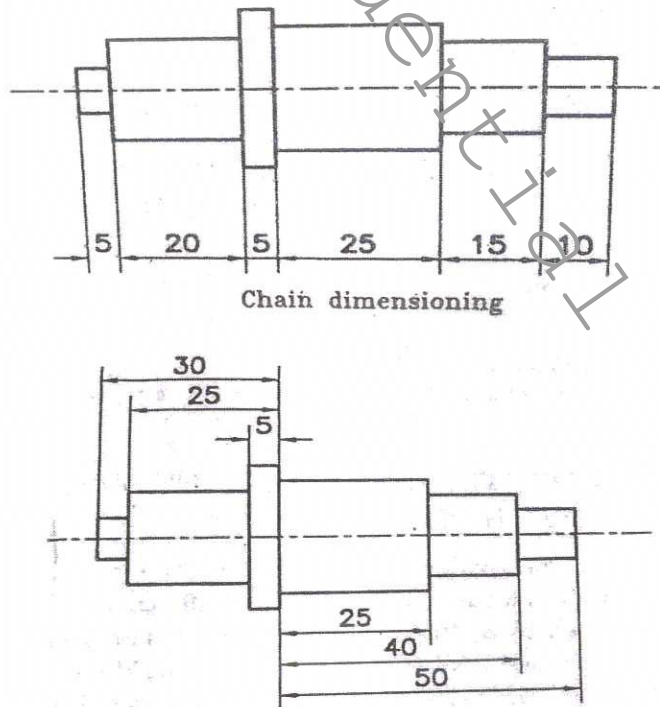

TED(21) 1005 A & TED(21)1005 B

SCHEME OF VALUATION

(Scoring Indicators)

QID : 2102220009					
REVISION : 2021			Course code : 1005		
Course Title : ENGINEERING GRAPHICS					
Qst No.	Scoring Indicators		Split up score	Sub Total	Total
PART - A					
I (1)		Continuous thin (straight) with zig-zags Chain thin	(0.5x2)	1	1
I (2)	Circle, Ellipse, Parabola, Hyperbola, Isosceles triangle		1	1	1
I (3)	Top view or Plan		1	1	1
I (4)	 <p style="text-align: center;">THIRD ANGLE</p>		1	1	1
I (5)	LINE		1	1	1
PART - B					
II (1)	 <p style="text-align: center;">Chain dimensioning</p> <p style="text-align: center;">Parallel dimensioning</p>			8	8

SCHEME OF VALUATION
(Scoring Indicators)

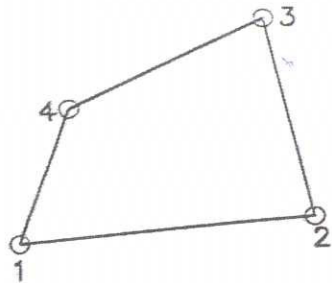

	X	Y
1	10	20
2	70	25
3	60	70
4	20	50

Dimensioning by co-ordinates

For drawing the figures (By any simple sketches to show chain, parallel and co-ordinate dimensioning) 4

For giving dimensioning values as per B.I.S. 2

Lettering of the figure 1

Neatness of the figure 1

II (2)

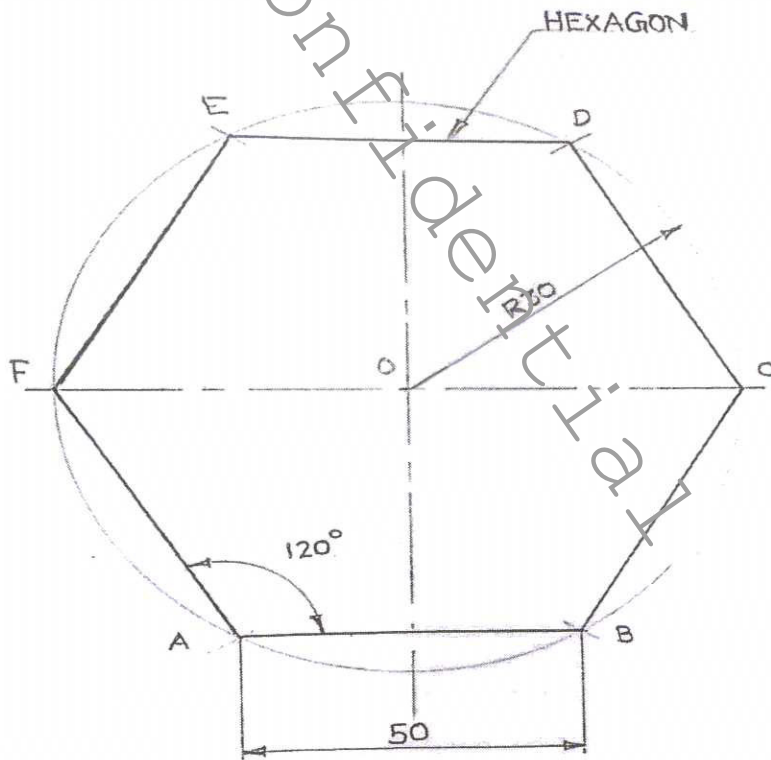

8

8

For drawing the figure (By any methods to draw a regular hexagon) 4

For giving proper dimensioning as per B.I.S. 2

Lettering of the figure 1

Neatness of the figure 1

SCHEME OF VALUATION
(Scoring Indicators)

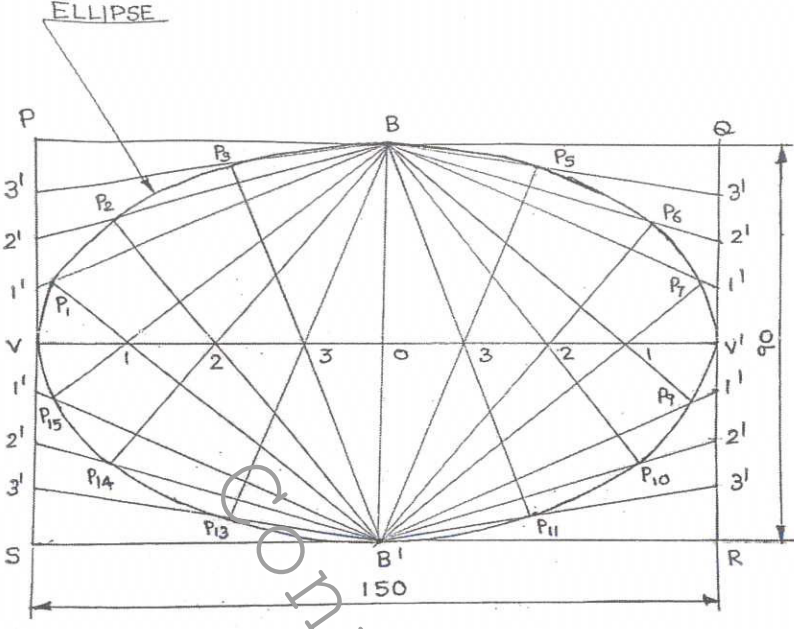
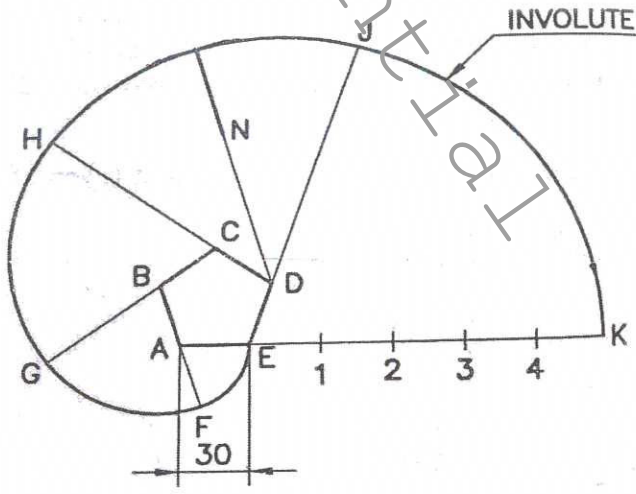
Qst No.	Scoring Indicators	Split up score	Sub Total	Total
II (3)	 <p align="center">Correct method for drawing an Ellipse by rectangular method</p> <p align="center">For giving proper dimensioning as per B.I.S.</p> <p align="center">Lettering of the figure</p> <p align="center">Neatness of the figure</p>	4	8	8
II (4)	 <p align="center">Involute of a regular pentagon</p> <p align="center">Correct method for drawing an involute of a regular pentagon</p> <p align="center">For giving proper dimensioning as per B.I.S.</p> <p align="center">Lettering of the figure</p> <p align="center">Neatness of the figure</p>	4	8	8

SCHEME OF VALUATION
(Scoring Indicators)

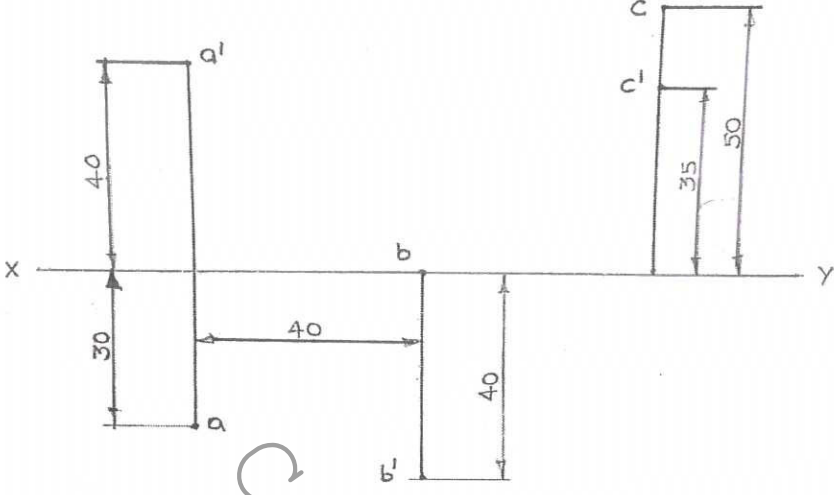
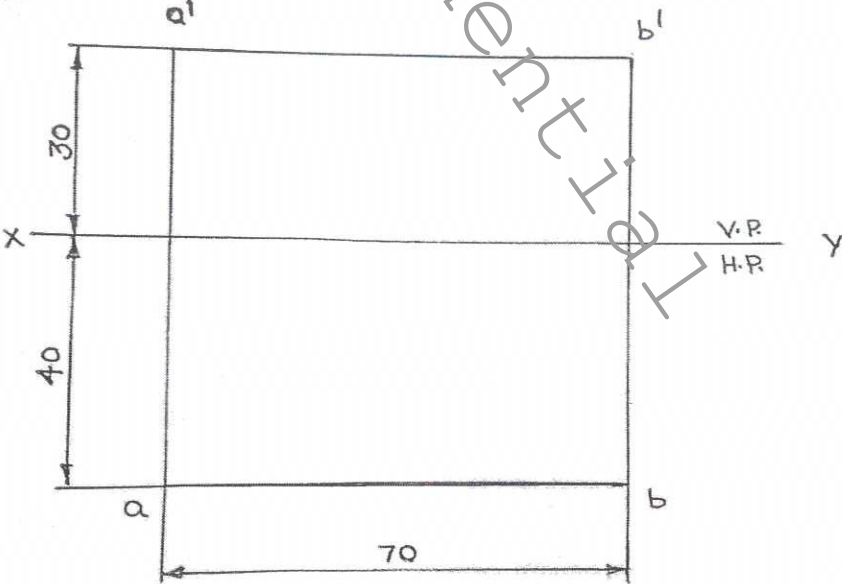
Qst No.	Scoring Indicators	Split up score	Sub Total	Total
II (5)			8	8
	To the projection of three points by keeping the distance between the projections as 40 mm.	2x3		
	For giving proper dimensioning as per B.I.S.	1		
	Neatness of the drawing	1		
II (6)			8	8
	Projection of the line	4		
	To mark the end points of lines	2		
	For giving proper dimensioning as per B.I.S.	1		
	Lettering of the figure	1		

SCHEME OF VALUATION
(Scoring Indicators)

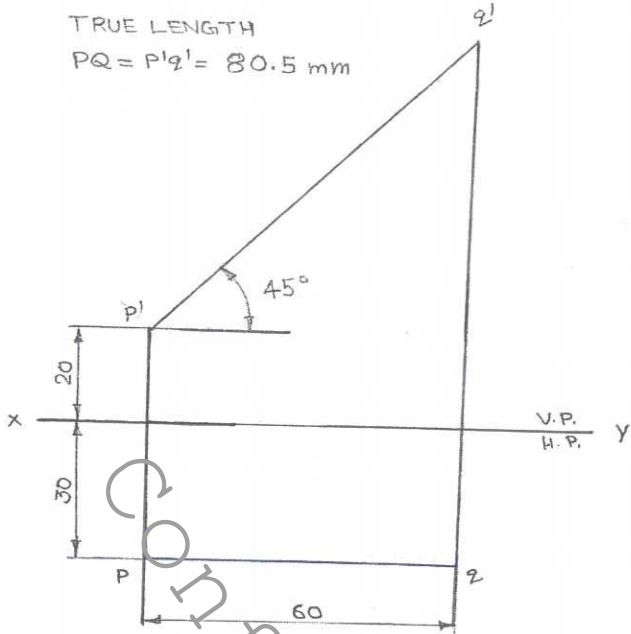
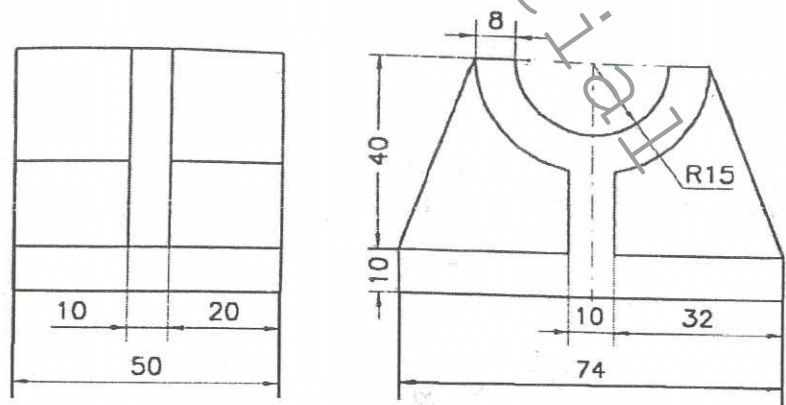
Qst No.	Scoring Indicators	Split up score	Sub Total	Total
II (7)	 <p>TRUE LENGTH $PQ = P'Q' = 80.5 \text{ mm}$</p> <p>$45^\circ$</p> <p>20</p> <p>60</p> <p>50</p> <p>x</p> <p>V.P.</p> <p>H.P.</p> <p>y</p> <p>p'</p> <p>q'</p> <p>p</p> <p>q</p>		8	8
	Projection of the line	4		
	To mark the end points of lines	1		
	For giving proper dimensioning as per B.I.S.	1		
	True length value	1		
	Neatness of the figure	1		
III (1)	<p align="center"><u>PART - C</u></p>  <p>8</p> <p>40</p> <p>10</p> <p>10</p> <p>32</p> <p>74</p> <p>R15</p> <p>10</p> <p>20</p> <p>50</p> <p>RIGHT SIDE VIEW</p> <p>FRONT VIEW</p>		15	15
	Front view in the direction of the arrow F.	7		
	Right-side views in the direction of the arrow R.	5		
	For giving proper dimensioning as per B.I.S.	2		
	Neatness of the figure	1		

SCHEME OF VALUATION
(Scoring Indicators)

Qst No.	Scoring Indicators	Split up score	Sub Total	Total
III (2)	<p>FULL SECTIONAL FRONT VIEW</p> <p>TOP VIEW</p>		15	15
	Full sectional front view in the direction of arrow F.	7		
	Top view in the direction of arrow T.	5		
	For giving proper dimensioning as per B.I.S.	2		
	Neatness of the figure	1		
III (3)			15	15
	Isometric view	10		
	Isometric angle line	2		
	For giving proper dimensioning as per B.I.S.	2		
	Neatness of the figure	1		

○○○○○○○○○○○○○○○○

Question Wise Analysis

COURSE NAME : ENGINEERING GRAPHICS

Q.No	Module Outcome	Cognitive Level	Marks	Time in minutes
I (1)	M1.02	Understanding	1	1
I (2)	M1.04	Understanding	1	1
I (3)	M2.01	Understanding	1	1
I (4)	M3.01	Understanding	1	2
I (5)	M4.04	Applying	1	1
II (1)	M1.03	Understanding	8	12
II (2)	M1.04	Understanding	8	12
II (3)	M1.04	Understanding	8	12
II (4)	M1.04	Understanding	8	12
II (5)	M2.02	Understanding	8	12
II (6)	M2.03	Applying	8	12
II (7)	M2.03	Applying	8	12
III (1)	M3.01	Understanding	15	30
III (2)	M3.02	Applying	15	30
III (3)	M4.02	Applying	15	30
TOTAL TIME				180

BLUE PRINT

Module	Hours/Module (h)	Marks/Module ($h_i/\Sigma H_i$) * 106 ($\pm 5\%$)	Types of questions							
			PART - A		PART - B		PART - C		TOTAL	
			No of Questions	Marks	No of Questions	Marks	No of Questions	Marks	No of Questions	Marks
I	15	35	2	2	4	32	0	0	6	34
II	12	29	1	1	3	24	0	0	4	25
III	9	21	1	1	0	0	2	30	3	31
IV	9	21	1	1	0	0	1	15	2	16
TOTAL	45	106	5	5	7	56	3	45	15	106

MARK DISTRIBUTION

COURSE NAME : ENGINEERING GRAPHICS

Blue Print

Cognitive Level Mark Distribution

Cognitive Level	Marks	% of Marks
Remembering	-	-
Understanding	59	56
Applying	47	44
Analysing	-	-
Evaluating	-	-
Creating	-	-
Total	106	100

Confidential

SCHEME OF VALUATION
(Scoring Indicators)

QID : 2102220009				
REVISION : 2021			Course code : 1005	
Course Title : ENGINEERING GRAPHICS				
Qst No.	Scoring Indicators	Split up score	Sub Total	Total
PART - A				
I (1)	(a) 30 degree – 60 degree set square. (b) 45 degree set square.	(0.5x2)	1	1
I (2)	Plain scale, Diagonal scale, Vernier scale	1	1	1
I (3)	Front view or Elevation.	1	1	1
I (4)	(a) Full sectional front view. (b) Full sectional top view. (c) Full sectional right side view. (d) Full sectional left side view.	Any two (0.5x2)	1	1
I (5)	Preparing architectural drawing, Interior design and modeling, Tool and fixture design, Production planning and control, Preparation of assembly lists and bill of materials, Computer aided inspections, Preparation of programs for CNC machines, Circuit layout and panel design, Mapping, building and drawing, Communication networks, Piping and instrumentation design, Automotive industries and Computer Aided Manufacturing(CAM).	Any two (0.5x2)	1	1
PART - B				
II (1)	<p align="center">Elements of dimensioning</p>	8	8	
	For drawing the figure (Any suitable figure to shows elements of dimensioning)			4
	Marking different elements of dimensioning			4

SCHEME OF VALUATION
(Scoring Indicators)

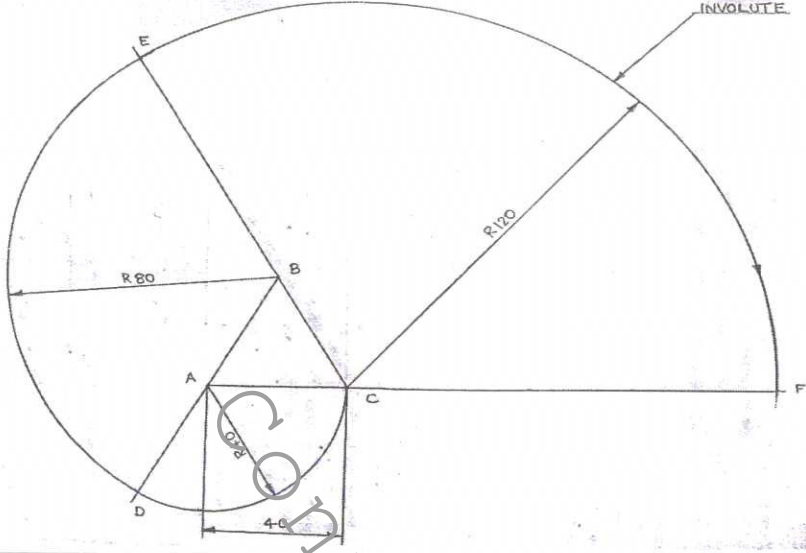
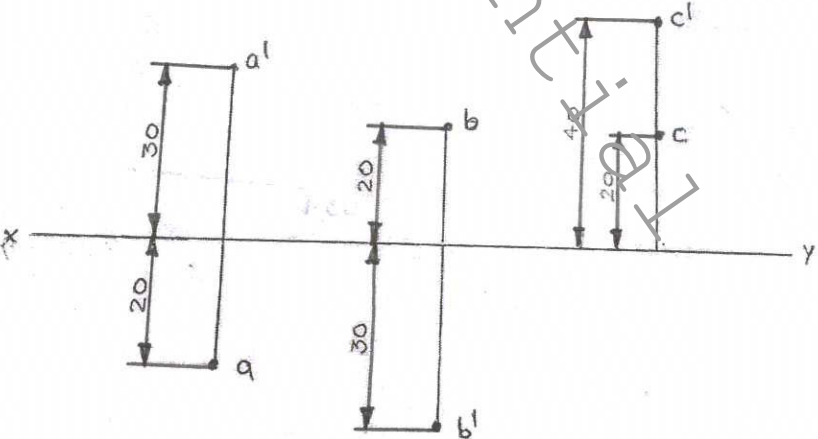
Qst No.	Scoring Indicators	Split up score	Sub Total	Total
II (4)			8	8
	Correct method for drawing an involute of an equilateral triangle	4		
	For giving proper dimensioning as per B.I.S.	2		
	Lettering of the figure	1		
	Neatness of the figure	1		
II (5)			8	8
	To the projection of three points	2x3		
	For giving proper dimensioning as per B.I.S.	1		
	Neatness of the drawing	1		

SCHEME OF VALUATION
(Scoring Indicators)

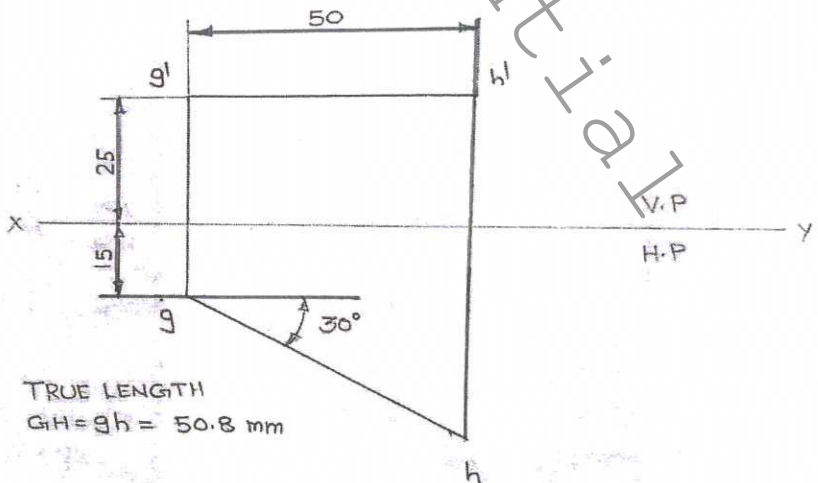
Qst No.	Scoring Indicators	Split up score	Sub Total	Total
II (6)			8	8
	Projection of the line	4		
	For giving proper dimensioning as per B.I.S.	2		
	Lettering of the figure	1		
	Neatness of the figure	1		
II (7)	 <p data-bbox="359 1601 630 1668">TRUE LENGTH $GH = gh = 50.8 \text{ mm}$</p>		8	8
	Projection of the line	4		
	True length value	1		
	For giving proper dimensioning as per B.I.S.	1		
	Lettering of the figure	1		
	Neatness of the figure	1		

SCHEME OF VALUATION
(Scoring Indicators)

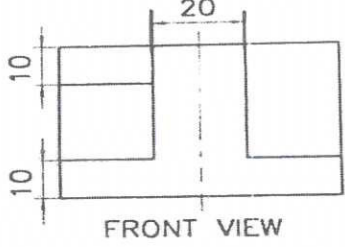
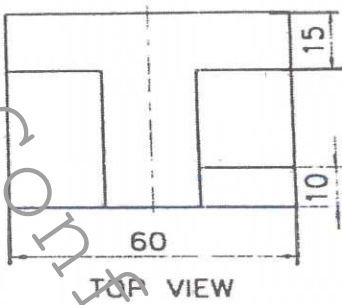
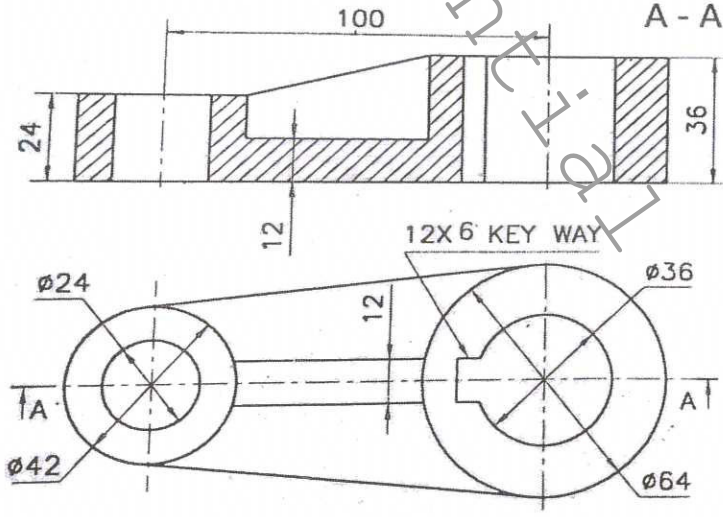
Qst No.	Scoring Indicators	Split up score	Sub Total	Total
III (1)	PART - C			
	 <p>FRONT VIEW</p>			
	 <p>TOP VIEW</p>			
	Front view in the direction of arrow F.	7		
	Top view in the direction of arrow T.	5		
	For giving proper dimensioning as per B.I.S.	2		
	Neatness of the figure	1		
III (2)	 <p>Sectional front and top views of a lever</p>			
	Full sectional front view in the direction of the arrow F.	7		
	Top view	5		
	For giving proper dimensioning as per B.I.S.	2		
	Neatness of the figure	1		

SCHEME OF VALUATION
(Scoring Indicators)

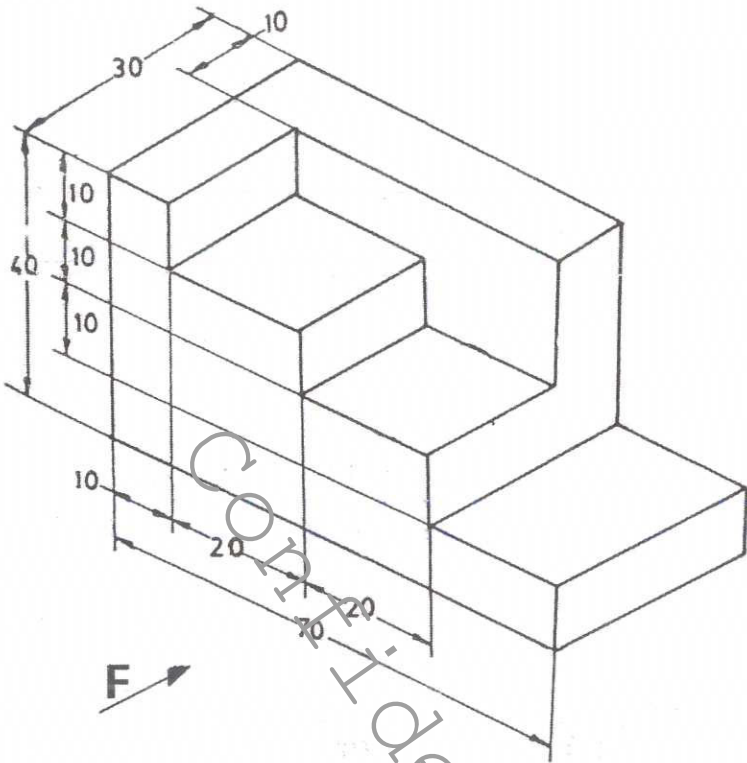
Qst No.	Scoring Indicators	Split up score	Sub Total	Total
III (3)	 <p align="center">Isometric view</p>		15	15
		Isometric view	10	
		Isometric angle line	2	
		For giving proper dimensioning as per B.I.S.	2	
		Neatness of the figure	1	

oooooooooooooooooooooooooooo