

DIPLOMA EXAMINATION IN ENGINEERING/TECHNOLOGY/
MANAGEMENT/COMMERCIAL PRACTICE — OCTOBER, 2018

CONSTRUCTION MATERIALS AND ENGINEERING

[Time : 3 hours

(Maximum marks : 100)

PART — A

(Maximum marks : 10)

Marks

I Answer *all* questions in one or two sentences. Each question carries 2 marks.

1. What is meant by slaking of lime ?
2. Define bulking of sand.
3. List out any four properties of distemper.
4. Define the terms (a) Closer (b) Corbel.
5. Write down any four factors to be considered while deciding the location of doors and window.

(5×2 = 10)

PART — B

(Maximum marks : 30)

II Answer any *five* of the following questions. Each question carries 6 marks.

1. Describe the classification of stones.
2. What are the ingredients of cement concrete ? Write down the functions of each ingredient.
3. Write down the uses and properties of Asbestos.
4. What are the characteristics of an Ideal paint ?
5. What are the causes of dampness ?
6. Write down the merits and demerits of steel formwork over timber formwork.
7. Write down the functions of a foundation.

(5×6 = 30)

PART — C

(Maximum marks : 60)

(Answer *one* full question from each unit. Each full question carries 15 marks.)

UNIT — I

- III (a) Explain the procedure for conducting slump test to measure the workability. 8
 (b) Describe the characteristics of a good timber. 7

OR

- IV (a) Explain the Consistency Test on cement. 8
 (b) Compare Clamp and Kiln burning in brick manufacturing. 7

UNIT — II

- V (a) Describe different types of glass. 8
 (b) Write short notes on Bitumen, Veneers, Plywood. 7

OR

- VI (a) Discuss on the constituents of paint. 8
 (b) Describe the properties and uses of Asphalt. 7

UNIT — III

- VII (a) What are the different types of prestressing of concrete ? Explain. 8
 (b) Discuss on defects in plastering. 7

OR

- VIII (a) What are the different types of pointing ? Explain. 8
 (b) Write down the general principles of brick masonry construction. 7

UNIT — IV

- IX (a) Explain the different types of window. 8
 (b) Discuss on types of ceiling. 7

OR

- X (a) Discuss on Classification of Arches. 8
 (b) Write down the requirements of a good staircase. 7

CONSTRUCTION MATERIALS AND ENGINEERING
(Civil Engineering)**ANSWER KEY**

(Maximum marks: 100)

Time: 3 hours

PART – A

(Maximum marks: 10)

I. Answer the following sentences in one or two sentences. Each question carries 2 marks.

1. When water is added to the quick lime in sufficient quantity, a chemical reaction takes place. Due to this chemical reaction, the quick lime cracks, swells and falls into a powder form which is calcium hydrate. This process is known as slaking.

2 Marks

2. The increase in volume of sand due to the presence of film of water around the sand particles is called bulking of sand. The finer the material more will be the increase in volume.

2 Marks

3. Following are the properties of distemper.

- On drying, the film of distemper shrinks. Hence it leads to cracking and flaking, if the surface to receive distemper is weak.
- The coatings of distemper are usually thick and they are more brittle than other types of water paints.
- The film developed by distemper is porous in character and it allows water vapour to pass through it. Hence it permits new walls to dry out without damaging the distemper film.
- They are generally light in colour and they provide a good reflective coating.
- They are less durable than oil paints.
- They are treated as water paints and they are easy to apply.
- They can be applied on brick work, cement plastered surface, lime plastered surface, insulating boards etc.
- They exhibit poor workability.
- They prove to be unsatisfactory in damp locations such as kitchens bathrooms etc.

(Any four points is only needed: 4 x ½ = 2 Marks)

4. (a) Closer is a portion of a brick cut in such a manner that its one long face remains uncut

(b) Corbel is a stone piece projecting beyond wall to support a structural member such as truss, beam etc.

(2 x 1 = 2 Marks)

5. The following factors are to be considered while deciding the location of door and windows.
- The doors and windows should be located in opposite walls facing each other for good ventilation and free air circulation.
 - From the point of utility and privacy of the occupants doors should preferably be located near the corner of a room.
 - The number of doors should be kept minimum to increase the utility of accommodation. The location and size of a door should be based on its functional requirements.
 - To derive maximum day lighting windows in a room should be located on the northern side.
 - The sill of the window should generally be located at a height of about 0.6 to 0.7 meter above the floor level.
 - Doors and windows should be so located that no dark corner or shadow is left in the room and light and ventilation are evenly distributed.
 - The location of the door should meet the functional requirement of the room.
- (Any four points is only needed: $4 \times \frac{1}{2} = 2$ Marks)**

PART – B

(Maximum marks: 30)

II. Answer any five of the following questions. Each question carries 6 marks.

I. The stones are classified as

(1) Geological - based on process of formation.

- Igneous – molten mass got cooled from the surface and solidified.
 - Plutonic Rocks – cooled slowly under a great thickness of solid crust.
 - Hypobysal Rocks – cooling occurs under thinner crust
 - Volcanic Rocks – Cooling takes pace more quickly.
- Sedimentary – due to the deposition of materials for a long period.
- Metamorphic – Sedimentary rock changed due to the subsection of high heat and pressure

(2) Physical – based on general structure of rocks.

- Stratified – They posses planes of stratification or cleavage and can be split along these plane easily.
- Unstratified – The structure may be crystalline, granular, or compact granular
- Foliated – They have a tendency to split in a definite direction only.

(3) Chemical – basis of their chief constituent material.

- Argillacious - The principle constituent of this is Clay and alumina.
- Silicious – The principle constituent of this is silica.
- Calcareous - The principle constituent of this is silica calcium carbonate.

(3 x 2 = 6 Marks)

2. Ingredients of cement concrete are

- 1) Cement – The main functions are
 - a) It bind the aggregates into a solid mass by virtue of its setting and hardening properties when mixed with water
 - b) It fills up the voids existing in the fine aggregate and makes the concrete impermeable.
 - c) It provides strength to the concrete on setting and hardening.
- 2) Fine aggregate - The main functions are
 - a) It fills the voids existing in the coarse aggregates.
 - b) It reduces shrinkage and cracking of concrete.
 - c) By varying the proportion of sand, concrete can be prepared economically for any required strength.
 - d) It helps in hardening of cement by allowing the water through its voids.
 - e) To form hard mass of silicates as it is believed that some chemical reaction takes place between silica of sand and the constituents of cement
- 3) Coarse aggregate - The main functions are
 - a) It makes solid and hard mass of concrete with cement and sand.
 - b) It increases the crushing strength of concrete.
 - c) It reduces the cost of concrete, since it occupies the major volume.
- 4) Water - The main functions are
 - a) It is the only ingredient that reacts chemically with cement and thus setting and hardening takes place.
 - b) It acts lubricant for the aggregate and makes the concrete workable.
 - c) It facilitates the spreading of concrete over the fine aggregate.

(4 x 1 ½ = 6 Marks)

3. Following are the properties of Asbestos (Any 6 properties and 6 uses is needed)

- a) The holes can be drilled and screws can be fitted on its surface.
- b) It can be cut into pieces.
- c) It is an excellent insulator for heat and electricity.
- d) It is fire proof and acid proof.
- e) It is flexible, soft and non porous.
- f) It is smooth like glass and silk.
- g) It possesses a good adsorption capacity.
- h) Its colour is brown grey or white.
- i) Its melting point is 1200⁰C to 1500⁰C.
- j) Its molecules are strongly bound together only in one direction and that is why it possesses very high tensile strength along the fibres.
- k) Its quality is critically affected by the length of fibres.
- l) Its specific gravity is 3.10.

(6 x ½ = 3)

Uses of Asbestos

- a) The asbestos sheets are used as roofing materials.
- b) The asbestos pipes are used to convey rainwater, seepage water, etc.
- c) The asbestos felt used as damp proof layer.
- d) It is used as the covering material for magnetic coils.
- e) It is used as the lining material for fuse box and switch box.
- f) It is used for insulating boilers, furnaces etc.
- g) It is used for preparing fire proof clothes, ropes, etc.
- h) It is used to form the asbestos paint.

(6 x ½ = 3)

(Total 3 + 3 = 6 Marks)

4. Characteristics of an ideal paint are

- a) It should possess a good spreading power. The maximum area of the surface should be covered by minimum quantity of the paint.
- b) It should be cheap and economical.
- c) It should be such that it can be easily and freely applied on the surface.
- d) It should be such that it dries in reasonable time and not too rapidly.
- e) It should be such that its colour is maintained for a long time.
- f) It should form a hard and durable surface.
- g) It should not be affected by the weathering action of the atmosphere.
- h) It should possess attractive and pleasing appearance.
- i) The surface coated with paint should not show cracks when the paint dries.
- j) When applied on surface it should form a thin film of uniform nature.
- k) It should not affect health of workers during its application.
- l) It should be free from defects of chalking and blistering.

(12 x ½ = 6 Marks)

5. Causes of dampness

- a) Moisture rising up the walls from ground
- b) Rain water penetrated from the not properly treated wall tops, travels downwards causes dampness.
- c) Rain water beating against not properly treated external walls will results in entering of rain water into walls and causes dampness.
- d) Due to Condensation of atmospheric moisture water is deposited on walls, floors and ceilings.
- e) Miscellaneous causes:
 - i) Poor drainage at the building site
 - ii) Imperfect orientation
 - iii) Imperfect roof slope
 - iv) Defective construction
 - v) Absorption of water from defective rain water pipes.

6 Marks

6. The merits of steel form work over timber form work
- Steel forms are more durable and have longer life as compared with timber forms.
 - The steel forms can be put to larger number of reuses
 - Steel forms can be installed and dismantled with greater ease and speed.
 - The quality of exposed concrete surface obtained by steel forms are good and it needs no further treatment.
 - Steel formwork does not absorb water from concrete and hence there is no chance of honey combing.
 - Steel forms does not shrink or distort and hence possible to achieve better workmanship and higher degree of accuracy.

(Any four merits is needed: $4 \times 1 = 4$ Marks)

The demerits of steel form work over timber form work

- Cost is more. Initial cost more than timber
- Skilled labour are required

(2 Marks)

(Total: $4 + 2 = 6$ Marks)

7. The functions of foundations are
- Reduction of load intensity.
 - Even distribution of load
 - Provision of level surface
 - Lateral Stability
 - Safety against undermining
 - Protection against soil movements

($6 \times 1 = 6$ Marks)

PART – C

(Maximum marks: 60)

(Answer one full question from each unit. Each full question carries 15 marks)

- III. a) A metal mould in the form of a frustum of cone open at both ends is used for conducting the tests. The top and bottom diameters are 10 cm and 20 cm respectively, the height is 30 cm. The mould is placed on a flat non absorbent surface and then filled with the specimen concrete in four different layers of equal thickness. Each layer is tamped 25 times by a 16 mm rod of 60cm length. After mould is completely filled, it is raised vertically. The concrete filling is allowed to subside or settle. The vertical settlement recorded in terms of mm is the slump.

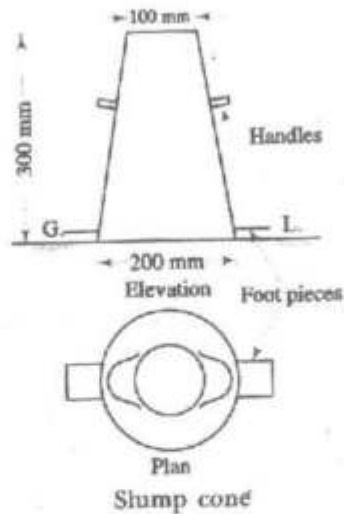

(Figure - 3 Marks
 Procedure - 5 Marks
 Total: 5 + 3 = 8 Marks)

b) The characteristic of a good timber are

- 1) Appearance
- 2) Colour
- 3) Defects
- 4) Durability
- 5) Elasticity
- 6) Fibres
- 7) Fire Resistance
- 8) Hardness
- 9) Mechanical wear
- 10) Shape
- 11) Sound
- 12) Smell
- 13) Strength
- 14) Structure
- 15) Toughness
- 16) Water Permeability

(Brief Description of any seven characteristics is needed: 7 x 1 = 7 Marks)

OR

- IV. a) The purpose of this test is to determine the percentage of water required for preparing cement paste. The following procedure is adopted.
- 1) Take 300 g of cement and add 30 percent by weight or 90 g of water to it.
 - 2) Mix water and cement on a non porous surface. The mixing should be done thoroughly.
 - 3) Fill the mould of Vicat Apparatus.

- 4) The plunger is attached to the movable rod of the vicat apparatus. The plunger is gently lowered on the paste in the mould.
- 5) The settlement of the plunger is noted. If the penetration is between 5mm to 7mm from the bottom of the mould the water added is correct. If penetration is not proper, the process is repeated with different percentage of water till the desired penetration is obtained.

(8 Marks)

b)

Sl No.	Item	Clamp burning	Kiln burning
1.	Capacity	About 20000 to 100000 bricks can be prepared in about two months.	25000 bricks can be prepared on an average per day.
2.	Cost of fuel	Low – Dried grass, cow dung etc. can be used.	High – Coal dust is to be used.
3.	Initial Cost	Very Low – as no structures are to be used	High – as permanent structures are to be built.
4.	Quality of bricks	Percentage of good quality bricks is small ie. about 60%	Percentage of good quality bricks is high ie. about 90%
5.	Regulation of fire	Not possible to control or regulate fire during the process of burning.	Fire is under control throughout the process of burning.
6.	Skilled supervision	Not necessary throughout the process of burning	Necessary throughout the process of burning
7.	Structure	Temporary structure	Permanent structure
8.	Suitability	Suitable when bricks are to be manufactured on a small scale	Suitable when bricks are to be manufactured on a large scale
9.	Time required for burning and cooling	It requires about 2 to 6 months for burning and cooling of bricks.	Actual time for burning of one chamber is about 24 hours and about 12 hours are required for the cooling of bricks.
10.	Wastage of heat	There is considerable wastage of heat and hot flue gas is not properly utilized.	The hot flue gas is used to dry and pre – heat raw bricks. Hence there is least wastage of heat.

(7 Marks)

V. a) The glass may be grouped into the following categories

- 1) Soda lime glass – This is a soft glass. This is a mixture of sodium silicate and calcium silicate. It is used in the manufacture of glass tubes and other laboratory apparatus.

- 2) Potash lime glass – This is also called bohemian glass or hard glass. It is the mixture of potassium silicate and calcium silicate. This type of glass is used in the manufacture of glass articles which have to withstand high temperatures such as combustion tubes.
- 3) Potash lead glass – This is also known as flint glass. It is mainly a mixture of potassium silicate and lead silicate. It is used in the manufacture of artificial gems, electric bulbs, lenses and prisms etc.
- 4) Common glass – This is also known as flint glass. It is mainly a mixture of sodium silicate, calcium silicate and iron silicate. It is mainly used in the manufacture of bottles for medicine.
- 5) Borosilicate glass – Borosilicate glass is made mainly of 70% to 80% silica and 7% to 13% boric oxide with smaller amount of alkalis and aluminium oxide. They are used for the manufacture of laboratory apparatus

(Brief description of the above types is needed: 8 Marks)

b) Bitumen

It is a hydrocarbon material of either natural or pyrogenous origin, which is completely soluble in carbon di sulphide. Uses of bitumen are

- 1) Used as road making material
- 2) Used as manufacturing material in the paints for industrial purposes.
- 3) Used in roofing, dap proofing felts, joint filler, and water proof packing paper.
- 4) Used for making insulating materials for buildings.

3 Marks

Veneer

Veneers are thin sheet of wood 0.4 mm to 6 mm in thickness obtained by different knife cutting processes. Depending upon the process of cutting Veneers can be classified as Rotary Veneers and Sliced Veneers. Rotary veneers are made from rotary cutting machine and sliced veneers are obtained from slicing. They are mostly used in manufacture of ply wood and other laminated boards.

2 Marks

Plywood

A board formed by gluing together three or more layers of veneers or piles is known as plywood. While manufacturing plywood the veneers are glued together usually with the grains of adjacent veneers running at right angles to each other. They are then pressed to form plywood in large hydraulic pressure under a pressure of 7 to 15 N / mm². The cross binding and odd

numbers of piles make the plywood of less shrinkage. This also makes it to resist warping and to have uniform strength in both the direction.

2 Marks

(Total: 3 + 2 + 2 = 7 Marks)

OR

VI. a) Ingredients of paints are

- 1) Base – The character and durability of the paint depends upon the base. It is the body of the paint. It reinforces the film of the paint after drying and minimizes shrinkage cracks formed in drying. Examples White lead, Lead oxide, Zinc oxide, Iron oxide
- 2) Vehicle – Vehicle is added to hold the ingredients in liquid suspension to allow them to spread evenly over the surface and to act as a binding agent. Example Linseed oil.
- 3) Drier – the drier is added to cause the vehicle to dry and harden quickly. Example Litharge, Red lead, Zinc sulphate.
- 4) Solvent or thinner – added to make the paint thinner and to flow freely under the brush. It helps to spread the paint evenly over the surface. Example turpentine.
- 5) Colouring Pigments – The desired final colour of the paint is obtained by adding colouring pigments. Example Lampblack, Red lead etc.

(8 Marks)

b) The following are the properties of Asphalt

- 1) It is a tough and durable material.
- 2) It is a waterproof material and can be easily cleaned.
- 3) It is good insulator of electricity, heat and sound.
- 4) It is non inflammable and non absorbent.
- 5) It is not attacked by acids and is safe against vermin.
- 6) It is resilient and reasonably elastic.

(6 x 1/2 = 3)

The uses of Asphalt are

- 1) Used as damp proof course
- 2) As waterproof layer for tanks, basements, swimming pools etc.
- 3) For preparing paints and roofing felts.
- 4) For constructing roads and pavements etc.

(4 x 1 = 4)

(Total: 3 + 4 = 7 Marks)

VII. a) Classification of prestressing are as follows

- 1) Classification based on the type of structure method of prestressing are classified as

- i) Linear prestressing- term applied to prestressing beam and columns in which the high tensile steel tendons under tension transmit an equal and opposite compressive force to concrete by bond or anchorage
 - ii) Circular prestressing – term applied to prestressing circular structures such as tanks pipes etc. in which high tensile steel wires are wound under tension in circles round the structure.
- 2) Classification based on method of applying of prestressing are classified as
- i) Pre tensioning system- In this method high tensile steel tendons are tensioned between fixed abutments before the concrete is poured round them. When the concrete reaches a required compressive strength, the prestress is transferred to it by releasing tendons at the abutment.
 - ii) Post tensioning system – In this concrete is poured first leaving ducts containing the high tensile steel tendons.

(2 x 4 = 8 Marks)

b) Defects in plastering are

- 1) Blistering of plastered surface – formation of small patches of plaster swelling out beyond the plastered surface, arising out of late slaking of lime particles in plaster.
- 2) Cracking – formation of cracks or fissures in the plaster work.
- 3) Crazeing- formation of a series of hair cracks.
- 4) Efflorescence – appearance of whitish patches due to the presence of salts in plaster making materials as well as building materials.
- 5) Flaking – formation of very loose mass of plastered surface due to poor bond between successive coats.
- 6) Peeling – complete dislocation of some portion of plastered surface resulting in the formation of patch.
- 7) Popping – formation of conical hole in the plastered surface due to the presence of some particles which expand on setting.
- 8) Rust stains – formed when plaster is laid on metal.
- 9) Uneven surface- due to poor workmanship.

(7 Marks)

OR

VIII. a) Different types of pointing are

- 1) Flush pointing – formed by pressing mortar in the raked joint and by finishing off flush with the edge of the masonry unit.
- 2) Recessed pointing – done by pressing the mortar back from the edges by 5 or more. Face of pointing kept vertical.
- 3) Rubbed keyed or grooved pointing – modification of flush pointing by forming a groove at its mid height by a pointing tool.
- 4) Beaded pointing – special type of pointing formed by steel or ironed with a concave edge. It gives good appearance but liable to damage

- //
- 5) Struck pointing – modification of flush pointing in which the face of the pointing is kept inclined with its upper edge pressed inside the face by 10 mm.
 - 6) Tuck pointing – formed by first pressing the mortar in the raked joint and finishing flush with the face. A narrow channel is cut at the centre of the groove and filled in or tucked in with white cement putty, kept projecting beyond the face of joint by 3 mm.
 - 7) V- pointing – formed by forming V-groove in the flush finishing face
 - 8) Weathered pointing – made by making a projection in the form of V- shape

(8 marks)

- b) The following are the general principles which should be adhered to for good brick masonry.
- i) The bricks selected for brick masonry should be hard, well burnt, sound with uniform colour shape and size. They should be free from cracks, holes, grit or lumps of lime. When two bricks are struck against each other a clear metallic ringing sound should be produced. They should not break when dropped from a height of 1 meter. The brick should not absorb water more than one fifth of its own weight when immersed in water for twenty four hours.
 - ii) The bricks should be properly soaked in water for at least two hours, before they are used in the construction work.
 - iii) The bricks should be laid on their beds with the frogs pointing upward.
 - iv) The use of brick bats should be avoided unless it is required for specific bond.
 - v) All the courses should be laid truly horizontal and all vertical joints should be truly vertical.
 - vi) Good quality of specific mortar should be used. The mortar should cover the bed and sides of the bricks. Proper care should be taken to obtain uniform mortar joint throughout the construction and thickness of joints should be always less than 12.5mm.
 - vii) The walls should be raised uniformly in proper bond. No part of the wall should preferably rise more than one meter than rest of it.
 - viii) In one day the height of construction of brick masonry should not exceed 1.5 meters.
 - ix) The joints at the face side should be raked to a depth 12 to 20mm, while mortar is green. This provides proper key for the plastering and pointing.
 - x) Hold fasts of doors and windows etc. are embedded in cement mortar or cement concrete.
 - xi) The finished brick work should be kept wet for a period of at least two to three weeks in case of lime mortar is used and for one or two weeks in case of cement mortar is used.
 - xii) If it is planned to increase the length of the wall under construction at a future date the wall is stopped with a toothed end.

xiii) In construction of a wall first of all two end corners are carefully laid, then in between portion of wall is built.

(7 Marks)

IX. a) Different types of windows are

- 1) Bay window
- 2) Corner window
- 3) Dormer window
- 4) Gable window
- 5) Skylight
- 6) Clerestory window
- 7) Casement window
- 8) Sash or glazed window
- 9) Sliding window
- 10) Louvered or venetian window
- 11) Wire gauged window
- 12) Metal windows
- 13) Fan lights

(Briefly description is needed: 8 Marks)

b) Different types of ceiling are

- 1) A.C Sheet ceiling
- 2) Fibre board ceiling
- 3) Plywood ceiling
- 4) Hardboard ceiling
- 5) Thermocole ceiling
- 6) Straw Board ceiling
- 7) Decorative ceiling
- 8) Moulded plaster of Paris ceiling boards
- 9) Plaster board ceiling

(Brief description is needed: 7 Marks)

OR

X. a) The different types of arches are classified as

- 1) Classification according to number of centers.
 - a) One centered arch
 - b) Two centered arch
 - c) Three centered arch
 - d) Four centered arch

- 2) Classification according to shape
 - a) Segmental arch
 - b) Semi circular arch
 - c) Horse shoe arch
 - d) Semi elliptical arch
 - e) Inverted arch
 - f) Pointed arch
 - g) Relieving arch
 - h) Flat arch
- 3) Classification based on materials and workmanship.
 - a) Stone arches
 - i) Rubble arch
 - ii) Ashlar arch
 - b) Brick arches
 - i) Rough arch
 - ii) Axed or rough cut arch
 - iii) Purpose made brick arch
 - c) Concrete arches
 - i) Concrete block units arch
 - ii) Monolithic arch

(8 Marks)

b) Requirements for good staircase are

- 1) Location – so located that sufficient light and ventilation is ensured. Should be easily accessible.
- 2) Length of flight – Maximum number of steps in a flight is 12 and minimum number is 3
- 3) Pitch of stair – Pitch should be made flatter by introducing landing. The slope of the stair should not exceed 40° and should not be flatter than 25°
- 4) Landing – width of landing should not be less than the width of stair.
- 5) Headroom – should not be less than 2.15m
- 6) Winders – as far as should be avoided.
- 7) Stair width- Sufficient width should be given.
- 8) Hand railings – should be provided at a height of 70 – 75 cm.
- 9) Risers and treads – Uniform Risers and treads should be provided.

(7 Marks)