

**DIPLOMA EXAMINATION IN ENGINEERING/TECHNOLOGY/MANAGEMENT/  
COMMERCIAL PRACTICE – NOVEMBER - 2020**

**ESTIMATING AND COSTING-III**

[Total Marks: 100]

[Time: 3hrs]

[Note: 1. Missing data may be suitably assumed.

2. Quantity shall be worked out in standard table form
3. Sketches accompanied]

**PART-A**

(Maximum Marks: 10)

1. Answer the following questions in one or two sentences. Each question carries 2 marks
  1. Mention the types of sub circuits
  2. What is the purpose of providing a vent pipe in a septic tank?
  3. Define the term aqueduct
  4. Differentiate between abutment and pier
  5. Define value analysis

**PART-B**

[Maximum Marks: 30]

II. Answer any five questions. Each question carries 6 marks

1. A factory consists of 30 fluorescent lamps each of 80 W rating. Calculate the total load and find out rating of Main switch, if the supply voltage is 240 V single phase.
2. What are the guidelines in determining the number of socket outlets?
3. Estimate the quantity of brickwork required for a well steining given the internal diameter as 2m and the thickness of wellsteining as 30cm. The depth of steining is 9m.
4. Work out the quantity of earthwork excavation for the pier shown in Figure V
5. An RCC water tank has internal dimensions of 5m x 4m x2m. If the wall thickness is 15cm and the base slab thickness is 20cm, calculate the quantity of RCC required for the water tank
6. Estimate the quantity of RCC 1:2:4 for the slab excluding steel of the culvert shown in figureIV
7. List out the benefits of value engineering.

**PART-C**

[Maximum Marks:60]

[Answer one full question from each unit]

**UNIT-I**

- III. a) Explain the procedures to be followed while carrying out the electrical estimation of a residential building (8)  
b) What are the guidelines to be followed while selecting the fan points in a building (7)

OR

- IV. Prepare a detailed estimate of the sanitary and water supply works of the plan shown in figure 1 (15)

**UNIT-II**

- V. Work out the quantities of brick work in cement mortar for the septic tank shown in figure II (15)

OR

- VI. Work out the quantities of steel reinforcement for the base slab of the retaining wall shown in figure III (15)

**UNIT-III**

- VII. Estimate the quantities of brickwork for the slab culvert shown in figure IV (15)

OR

- VIII. Estimate the quantities of brickwork for the pier shown in figure V (15)

**UNIT-IV**

- IX. Explain the various phases of Value Engineering Job Plan (15)

OR

- X).a) Explain how value management can be applied in construction (8)

- b) What are the factors which contribute to poor value (7)

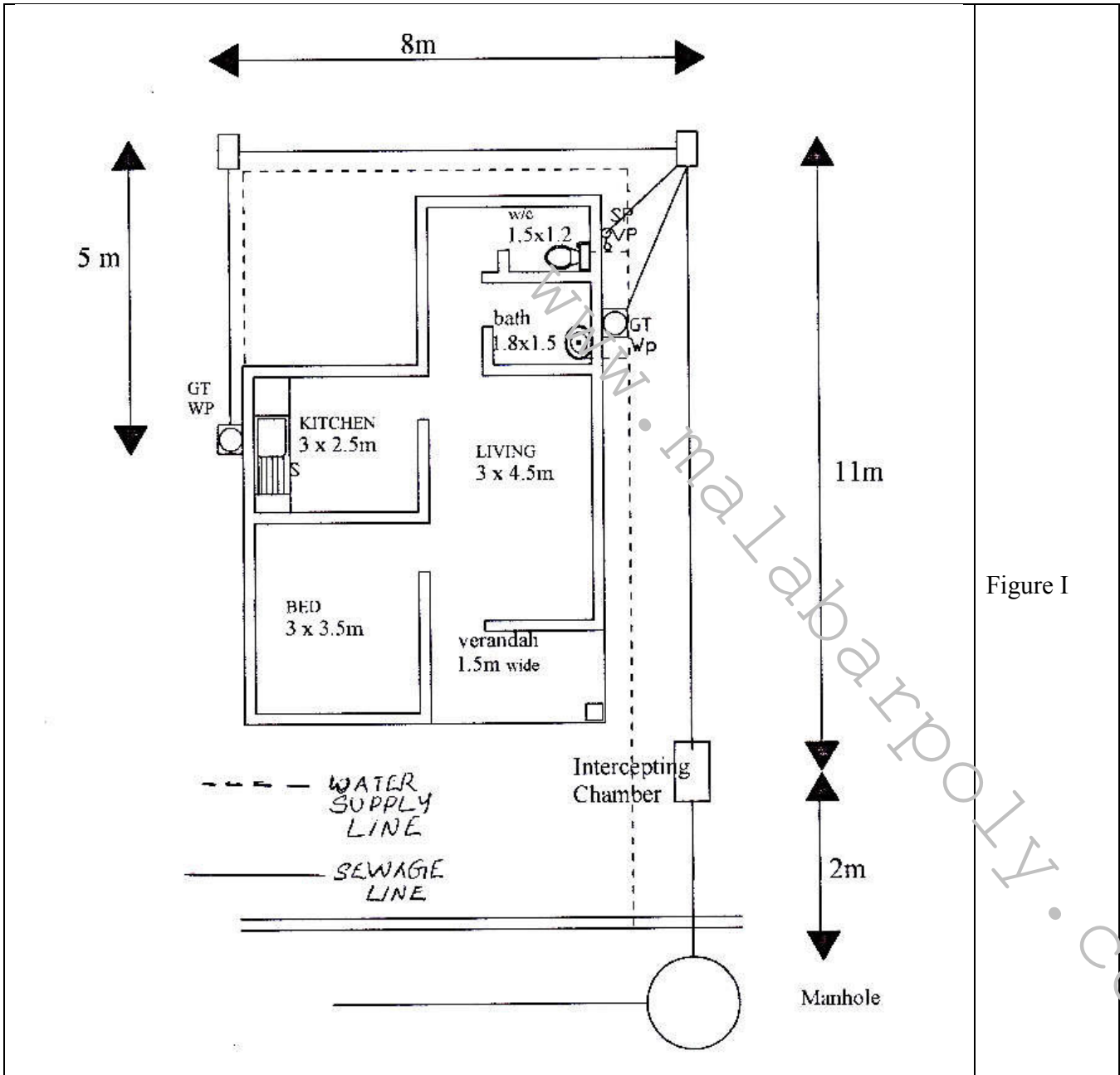

Figure I

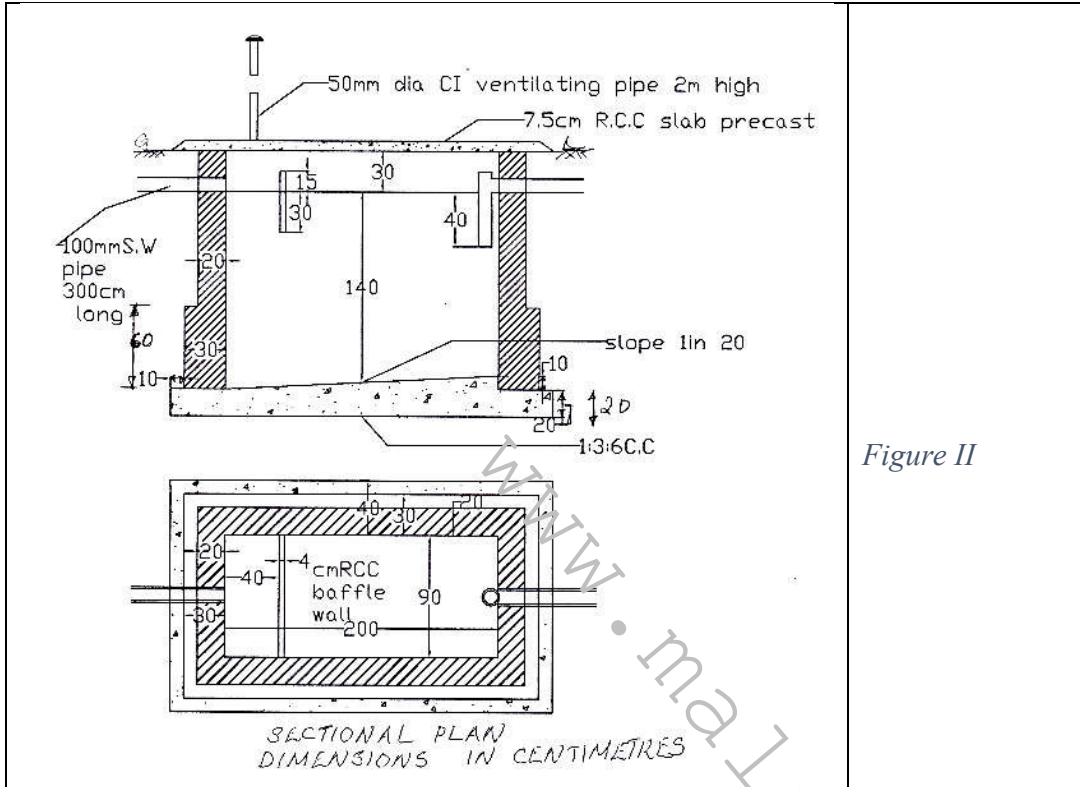

Figure II

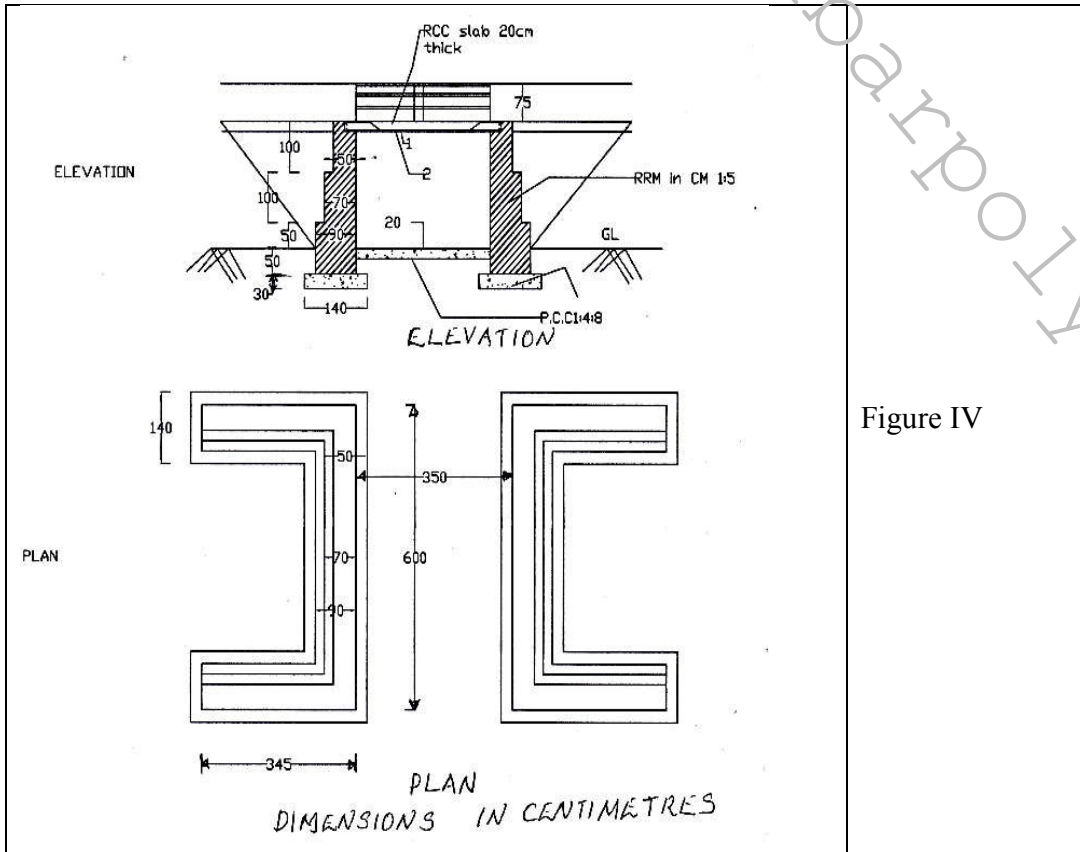

Figure IV

R.C.C. RETAINING WALL  
CROSS SECTION

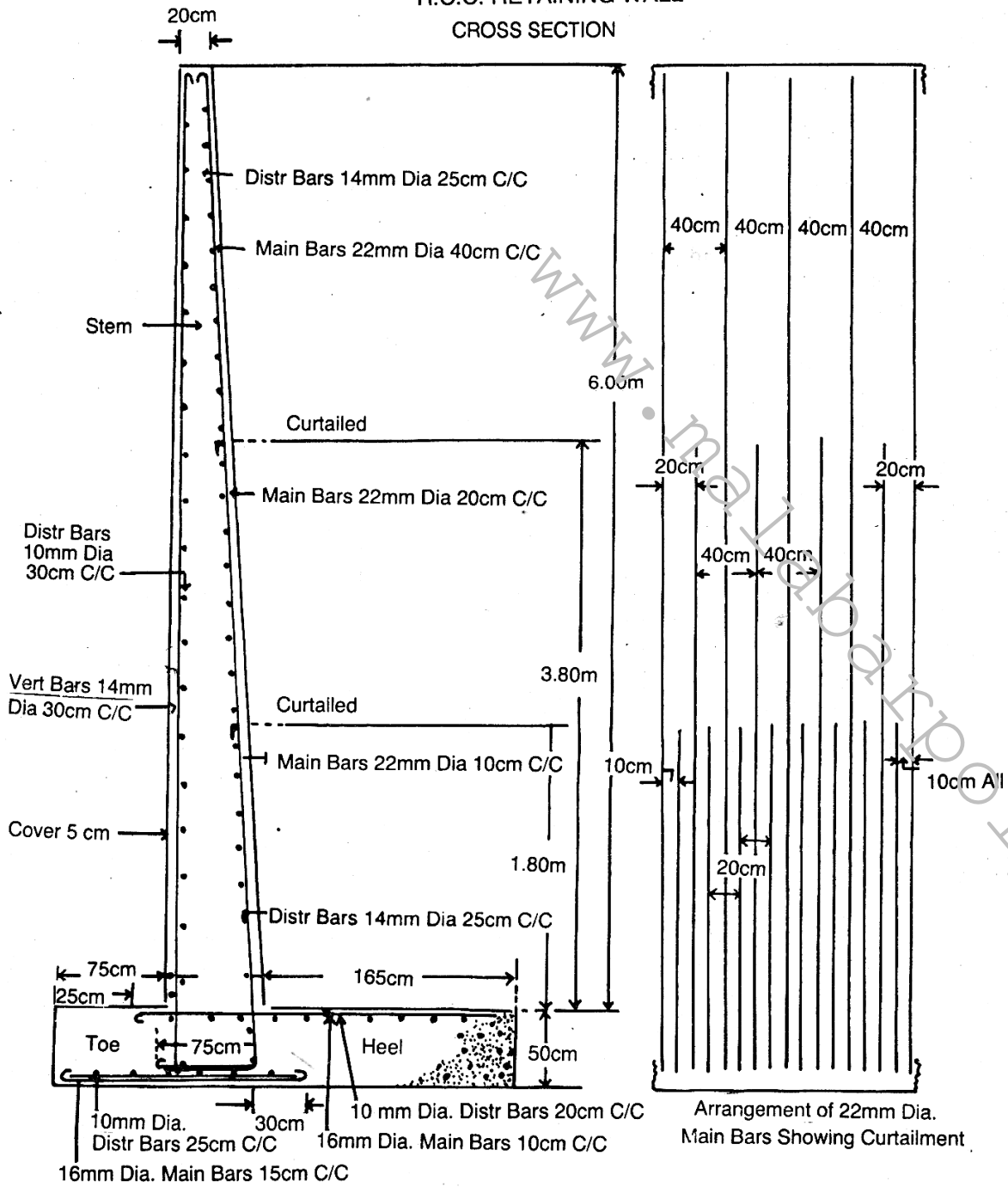

Figure III

