

278
14/11/23

D-4

NOV-23

SCHEME OF VALUATION

Scoring Indicators

Revision: 2015

Course Code: 3011

Course Title: Construction Materials and Engineering

QST NO	Scoring indicator	Split up Score	Sub Total	Total
Part A				
1	heating to high temperatures in air or oxygen	2	10	10
2	They are generally light in colour. The coatings are generally thick. They give reflective coating. They are less durable than oil paints but are cheaper	2		
3	Corbel - a projection jutting out from a wall to support a structure above it. Coping - the top, typically curved or sloping, course of a brick or stone wall.	2		
4	Closer - portion of the brick cut along the length Bat - the brick is cutted along the width	2		
5	the ridge of a roof is the peak where two opposing roof planes meet	2		
Part B				
1	Igneous rock is formed through the cooling and solidification of magma or lava. plutonic Rocks - formed when the hot molten rock (magma) cools down slowly beneath the earth's crust at great depth. Examples are gabbro and granite rocks. Hypabyssal rock - formed at medium to shallow depths (>2 km) within the crust, example - dolerite volcanic Rocks – formed at earth surface example - basalt	2 2 2	6	
2	<pre> graph TD A[Calcareous Material Lime stone] --> B[Crusher] C[Argillaceous Material Clay] --> D[Wash mill] B --> E[Storage basins silos] D --> F[Storage basins silos] E -- channel --> G[Wet grinding mill Ball mill to make slurry] F -- channel --> G G --> H[Blending of slurry to correct composition] H --> I[Storage of corrected slurry] I --> J[Corrected slurry fed to rotary kiln from upper end] K[Fuel fed from lower end coal, oil or natural gas] --> J J --> L[Slurry converted into clinkers] L --> M[Clinkers are ground in Ball mill] N[Addition of 2 to 3% of gypsum] --> M M --> O[Cement silos] O --> P[Packing plant] </pre> <p>Flow diagram of wet process</p>	6	6	
3	Properties : <ol style="list-style-type: none"> 1. Stability 2. Durability 3. Flexibility 4. Fatigue Resistance 5. Skid Resistance 6. Impermeability 7. Workability 	3	6	

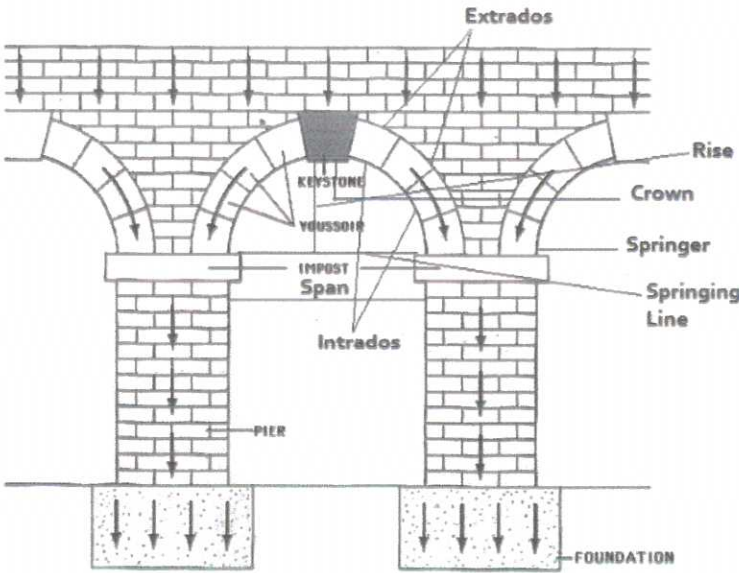
	<p>Uses t</p> <ol style="list-style-type: none"> 1. Electrical use 2. Roadway construction 3. Asphaltic paint 4. Asphalt concrete 	3		
4	<p>It should be strong enough to withstand all types of dead and live loads. It should be rigidly constructed and efficiently propped and braced both horizontally and vertically, so as to retain its shape. The joints in the formwork should be tight against leakage of cement grout. Construction of formwork should permit removal of various parts in desired sequences without damage to the concrete. The material of the formwork should be cheap, easily available and should be suitable for reuse. The formwork should be set accurately to the desired line and levels should have plane surface. It should be as light as possible. The material of the formwork should not warp or get distorted when exposed to the elements. It should rest on firm base.</p>	6	6	
5	<p>Causes of Dampness in Buildings –</p> <ul style="list-style-type: none"> • Old bathroom pipes Damaged seals around baths and showers. • Corroded water pipes that are inside the walls. • Old bathroom pipes. • Plumbing for central heating, kitchens and bathrooms. • Moisture entrapped during construction. • Defective orientation of building. • Drain ability of soil. • Poor Quality of Construction Material 	6	6	
6	 <p style="text-align: center;">Parts Of Arch</p>	6	6	

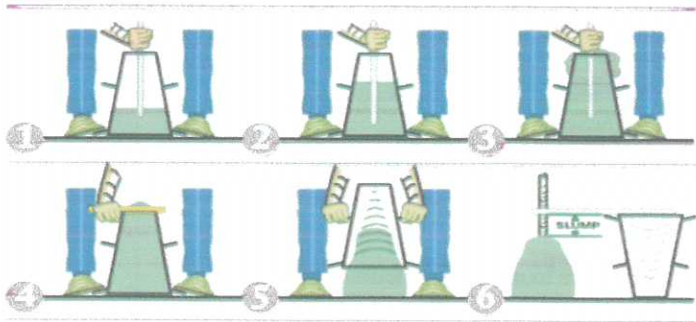
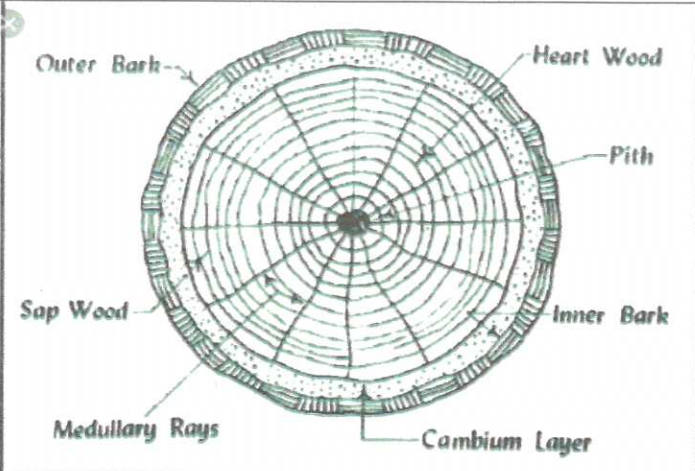
7	<ul style="list-style-type: none"> • Strength and stability. • Resistance to weather and ground moisture. • Durability and free from maintenance. • Fire resistance. • Resistance to passage of heat. • Resistance to passage of sound 	6	6	30.
Part C				
III a	<p>The volume of dry sand increases due to absorption of moisture. These volume increase of dry sand is known as bulking of sand. When dry sand comes in contact with moisture, a thin film is formed around the particles, which causes them to get apart from each other. This results in increasing the volume of sand.</p> <p>It has been found that 4% moisture content (by weight) of dry sand may increase its volume up to 25 – 30% depending upon the grading. Finer sand particles result in extreme bulking.</p>	3 3	6	
b	<p>Concrete slump test or slump cone test is to determine the workability or consistency of concrete mix prepared at the laboratory or the construction site during the progress of the work.</p> 	3 6	9	15
IV a		7		
b	<p>This is the process of reducing the moisture content in wood so as to increase its durability. Generally two types of moisture is present in wood.</p> <ul style="list-style-type: none"> • Free water • Bound water <p>During seasoning, we remove free water. The point at which entire free water gets removed is called as Fiber Saturation point.</p> <p>Advantages of seasoning</p> <ul style="list-style-type: none"> • Wood can be burnt readily if used as fuel. • It reduces the weight of the timber which in turn lowers the transportation cost and dead load of the structure. • Imparts hardness and strength. 	3		

	<ul style="list-style-type: none"> • Workability of timber gets increased at the time of conversion. • It increases the resistance of wood against the attack of fungi and insects. • vi. It increases the adhesive capacity the protective and decorative solutions over the timber. 	5	8	
V a	<p>Bitumen is a sticky, black, and highly viscous liquid or semi-solid form of petroleum. It may be found in natural deposits or may be a refined product, and is classed as a pitch.</p> <p>veneer refers to thin slices of wood and sometimes bark, usually thinner than 3 mm (1/8 inch),^[1] that typically are glued onto core panels (typically, wood, particle board or medium-density fiberboard) to produce flat panels such as doors, tops and panels for cabinets, parquet floors and parts of furniture.</p> <p>Plywood is a material manufactured from thin layers or "plies" of wood veneer that are glued together with adjacent layers having their wood grain rotated up to 90 degrees to one another. It is an engineered wood from the family of manufactured boards which includes medium-density fibreboard (MDF) and particle board (chipboard).</p>	3	2	2
b	<ol style="list-style-type: none"> 1. It is elastic; because of this property a rubber band can be stretched to 9 or 10 times its original length and when the load is removed it regains its original length. 2. It is strong and tough. Because of this property it can be put to use even under abnormal conditions. 3. It is highly impermeable to both water and air and therefore, it can be used to retain water as in rubber bottles, hoses etc. 4. It exhibits a great resistance to abrasion, tearing and cutting over a wide range of temperature—7 to 115°C. 5. It is a bad conductor of heat. 6. It can contain liquids and gases. 7. The synthetic rubber offers great resistance to acids, petroleum products etc. 9. Its properties such as hardness, strength, abrasion, resistance etc., can be modified to the desired extent by compounding techniques. 	8	8	15
VI a	<div style="border: 1px solid black; padding: 5px;"> <p style="text-align: center;">Characteristics of a good varnish</p> <ul style="list-style-type: none"> It should dry rapidly It should form a hard film on drying. It should not crack on drying. It should have sufficient elasticity. It should be durable and weather resistant. It should give uniform and pleasing appearance. It should not hide the natural grain of the inner surface of timber. The colour of Varnish should not fade away with time. </div>	6	6.	

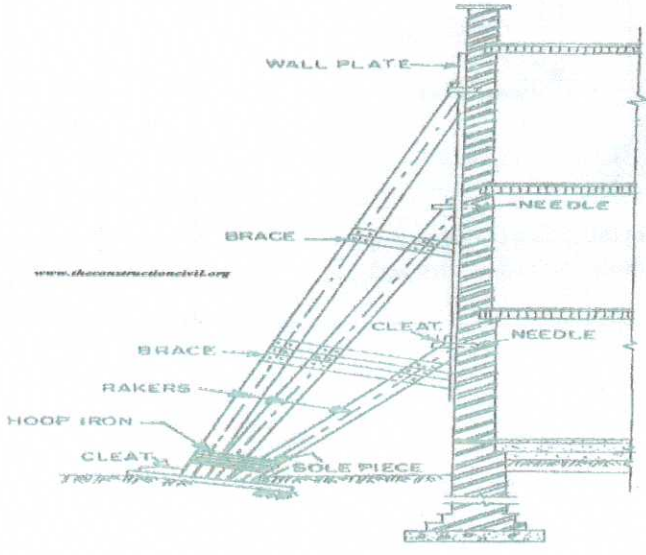
b	<p>1 Paint should form hard and durable surface.</p> <ol style="list-style-type: none"> 1. It should give attractive appearance. 2. It should be cheap and readily available. 3. It can be applied easily to the surfaces. 4. It should have good spreading quality, so as to cover maximum area in minimum quantity. 5. It should dry in reasonable time. 6. It should not show hair cracks on drying. 7. It should form film of uniform colour, on drying. 8. It should be stable for a longer period. 9. It should not be affected by atmospheric agencies 	9	9	15
VII a	<p>Pre-tensioning method In this method, prestressing is induced (the tendons are tensioned) before the concrete is placed. It is done in factories. In this method, the tendons are enclosed temporarily against some abutments and then they are pulled by using jack type devices. The concrete is placed while maintaining the tension. When concrete is hardened sufficiently, the tendons are released slowly or cut. This will transfer prestress from steel to concrete through bond.</p> <p>This type of prestressing method is commonly used for small sized members like beams, slabs, piles, sleepers and electric poles, etc which can be casted easily in factories.</p> <p>Post-tensioning method In this method, the prestress is induced or tendons are tensioned only after the concrete has hardened. In this system, the concreting is done first and a duct is formed in the member with tube or with a metal sheathe. When concrete has sufficiently hardened then tendons or cable is transferred from the tendon to the member through anchorage wedges. The space between the tendon and the duct is filled with cement grout.</p> <p>Post tensioning method of prestressing is used for both precast and cast in situ construction. It is used for large span structures like bridges.</p>	3 3	6	
b	<p>Shoring' is the means of providing temporary support to attain stability of the structure</p> <p>Shoring are classified into the following three classes either on the basis of their supporting characteristics or their position in the space:</p> <ol style="list-style-type: none"> 1. Raking or Inclined Shores 2. Flying or Horizontal Shores 3. Dead or vertical shores. 	3 3 3	9	

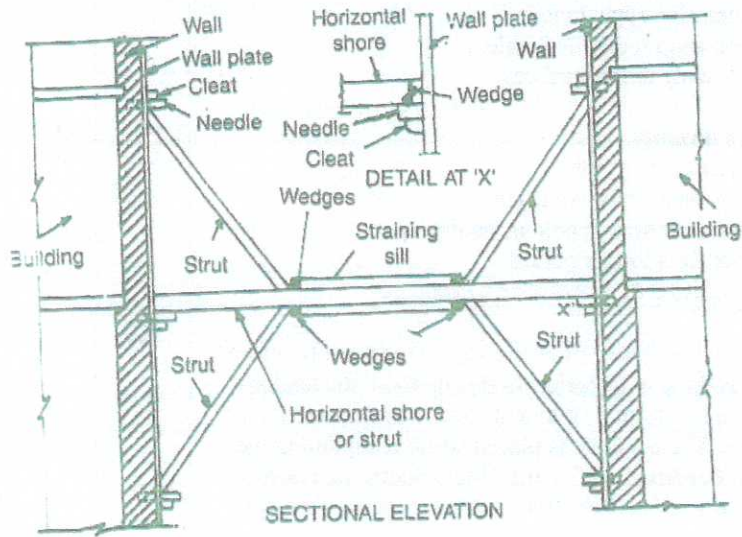

Details of a single flying shore.

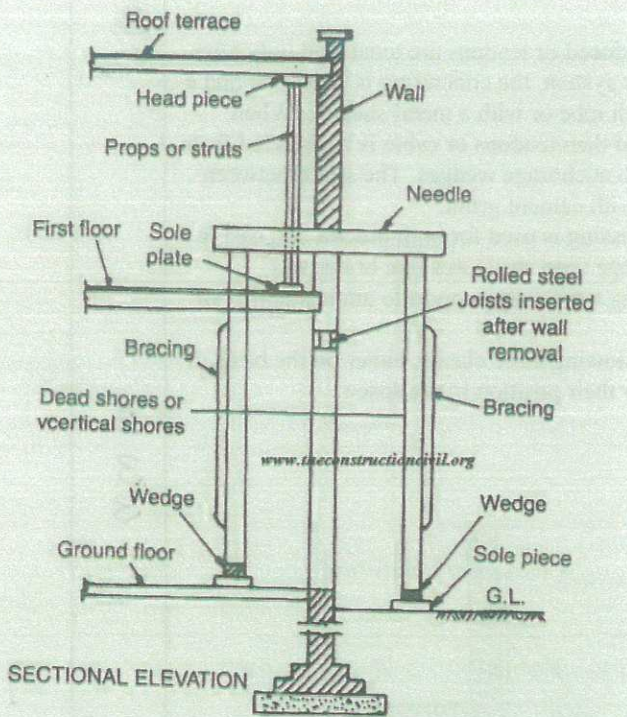

Use of dead-shores in rebuilding or deepening of foundations, or for removing lower part of defective wall.

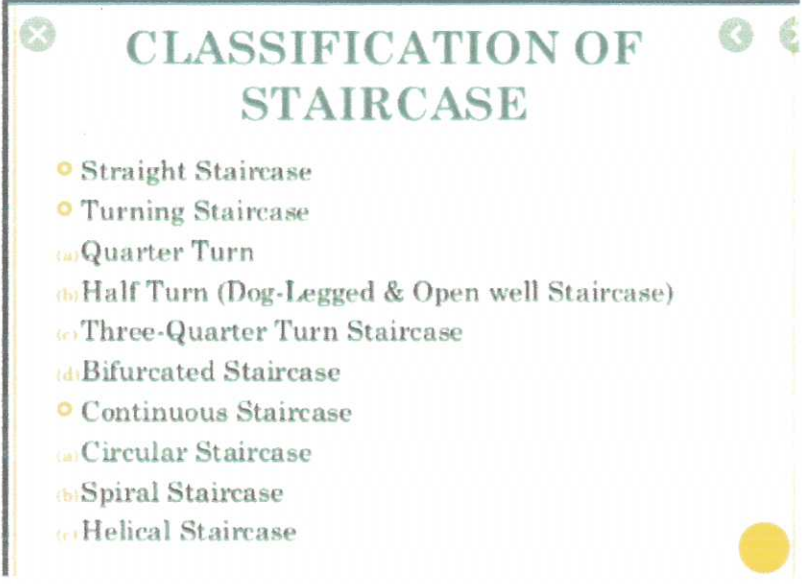
VIII a	<p>Difference between english bond and flemish bond are as follows:</p> <ol style="list-style-type: none"> 1. English bond is much stronger than flemish bond for the walls thicker more than 1½ brick. 2. Flemish bond shows more attractive and pleasing appearance of masonry work. 3. Flemish bond is economical as it uses broken brick bats, although it requires some extra mortar for additional joints. 4. Uses of flemish bond is a bit difficult than english bond. Flemish bond requires more skilled labour and supervision. 	8	8	
b	<ul style="list-style-type: none"> • Beaded pointing. • Flush pointing. • Recessed pointing. • Rubbed or keyed or grooved pointing. • Struck pointing. • Tuck pointing. • Vee – pointing. • Weathered pointing. 	7	7	15
IX a	<p>Fixed windows</p> <ul style="list-style-type: none"> <input type="checkbox"/> Sliding windows <input type="checkbox"/> Pivoted windows <input type="checkbox"/> Double hung windows <input type="checkbox"/> Louvered windows <input type="checkbox"/> Casement windows <input type="checkbox"/> Metal windows <input type="checkbox"/> Sash windows <input type="checkbox"/> Corner windows <input type="checkbox"/> Bay windows <input type="checkbox"/> Dormer windows <input type="checkbox"/> Clerestory windows <input type="checkbox"/> Lantern windows <input type="checkbox"/> Gable windows <input type="checkbox"/> Ventilators <input type="checkbox"/> Skylights 	8	8	
b	 <p>CLASSIFICATION OF STAIRCASE</p> <ul style="list-style-type: none"> • Straight Staircase • Turning Staircase <ul style="list-style-type: none"> (a) Quarter Turn (b) Half Turn (Dog-Legged & Open well Staircase) (c) Three-Quarter Turn Staircase (d) Bifurcated Staircase • Continuous Staircase <ul style="list-style-type: none"> (a) Circular Staircase (b) Spiral Staircase (c) Helical Staircase 	7	7	15

X a	<ul style="list-style-type: none"> • Conventional ceiling... • Suspended ceiling. ... • Tray ceiling. ... • Coffered ceiling. ... • Cathedral ceiling. ... • Coved ceiling. ... • Shed ceiling. ... • Beam ceiling. 	7	7	
b	<p style="text-align: center;">Substructure</p> <ul style="list-style-type: none"> • The substructure is the lower portion of the building, which is located below ground level which transmits the load of the superstructure to the sub soil. • it includes • Foundations <hr/> <p style="text-align: center;">Super Structure</p> <ul style="list-style-type: none"> • The superstructure is that part of the building which is above the ground and which serves the purpose of building's intended use. • It includes • <i>Plinth</i> • <i>Wall and columns</i> • <i>Beams</i> • <i>Arches</i> • <i>Roofs and slabs</i> • <i>Lintel and arches</i> • <i>Chajjas</i> • <i>Parapet</i> • <i>Steps and stairs</i> 	8	8	15