

Scheme - Engg: Graphics

1. T-square or minidrafts
 Set squares, Protractor,
 Instrument box, Engineer's scale set,
 Pencils etc.

any two - 2

2. Systems of projection

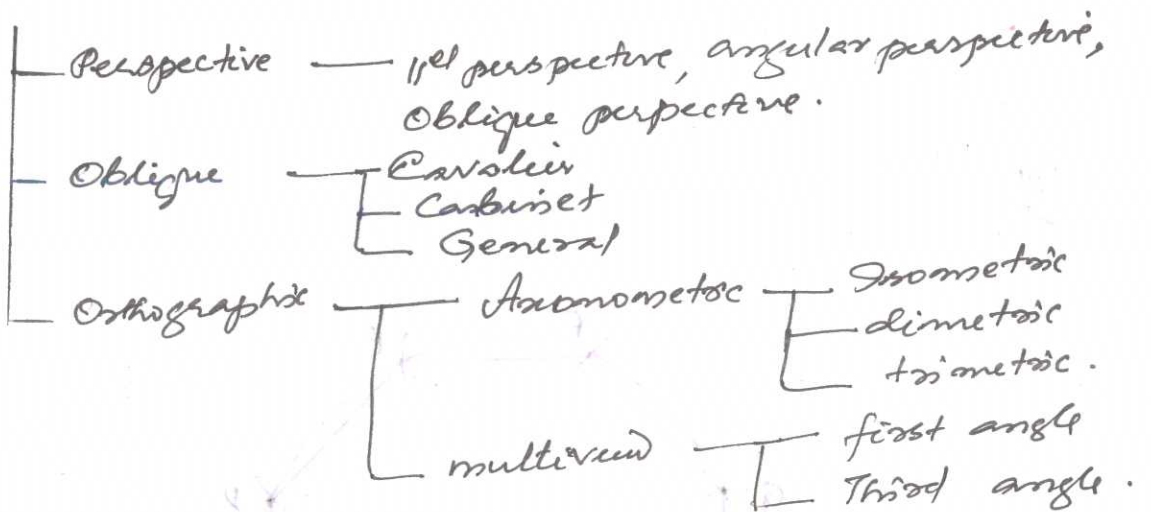

3.

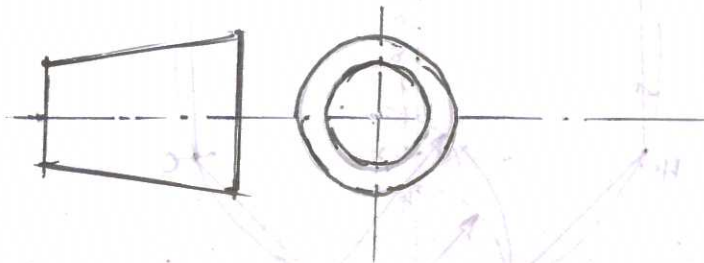

4. Helix is defined as a space curve generated by a point which moves on the surface of a cylinder or cone in a circumferential direction at a constant angular speed.

5. A length twice that of the ordinate is called double ordinate.

PART - B

II

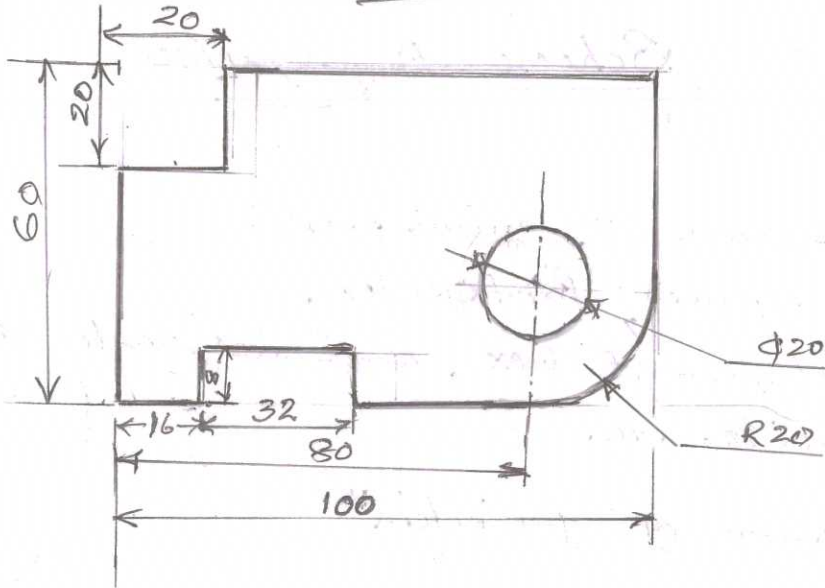

III

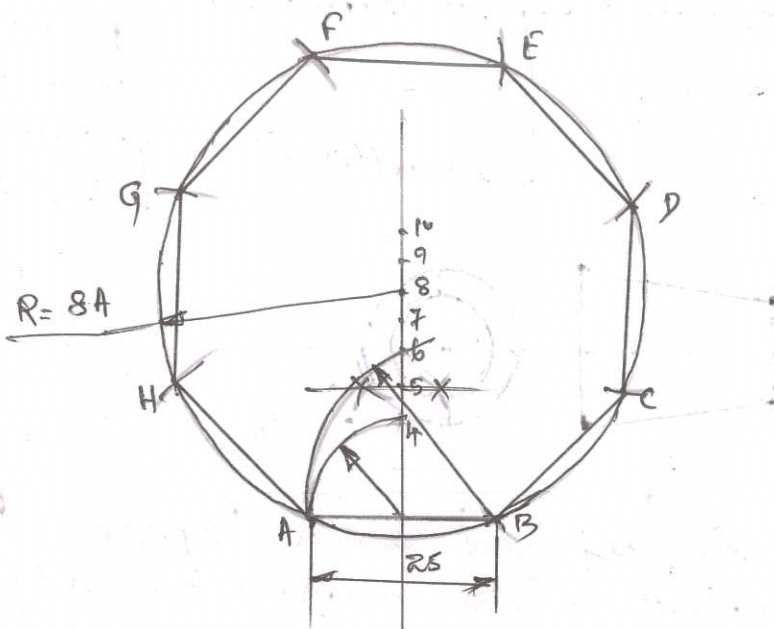

17

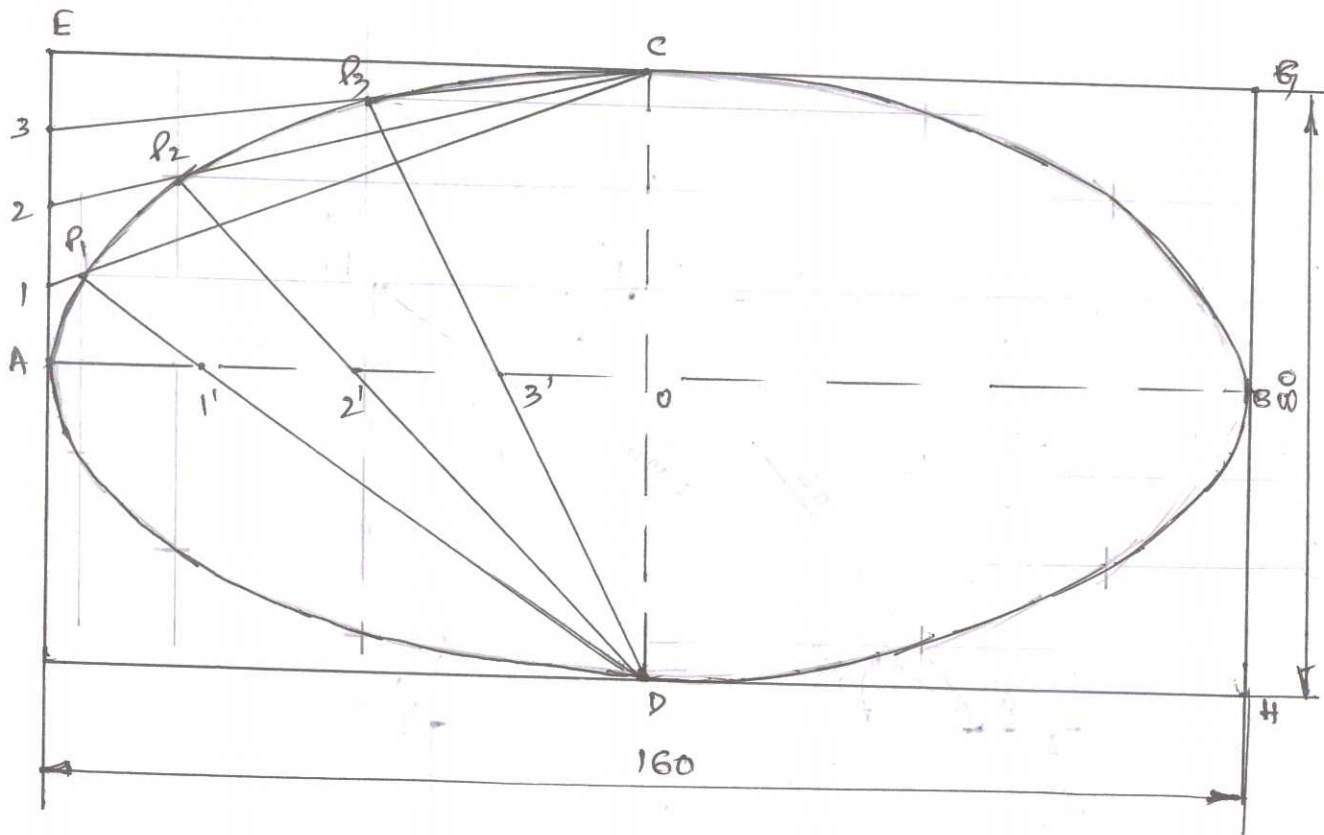

18

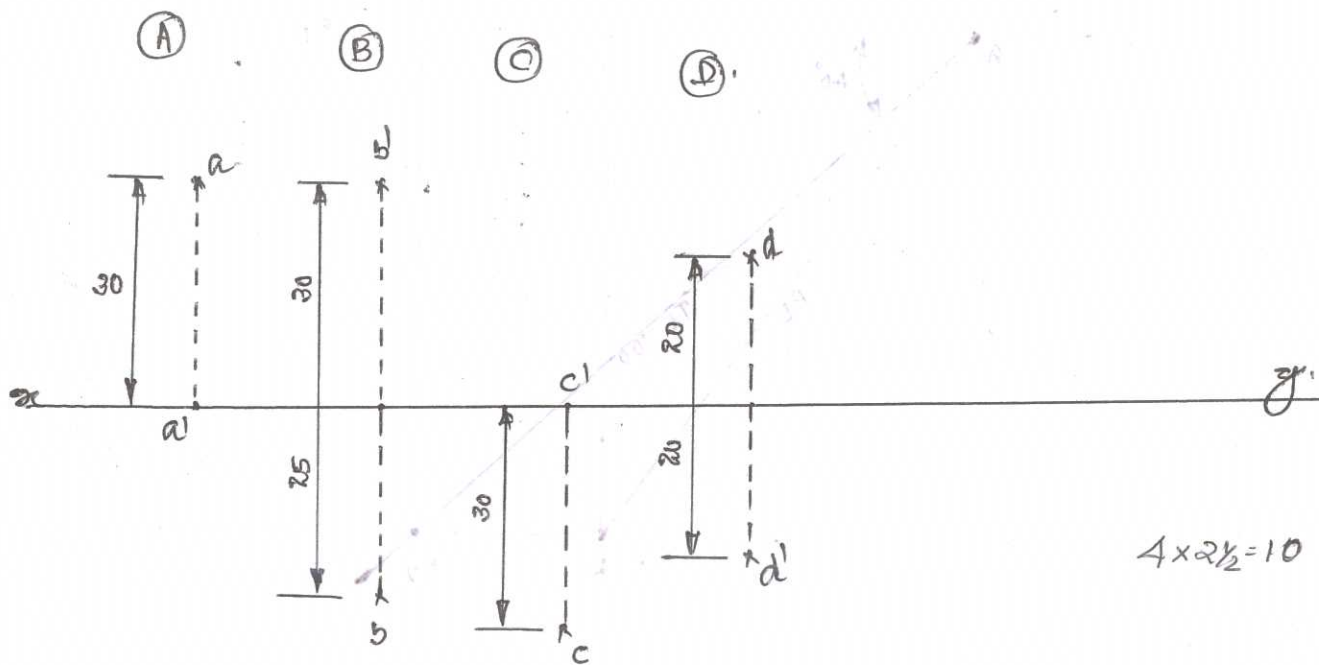

$4 \times 2 \frac{1}{2} = 10$

VII

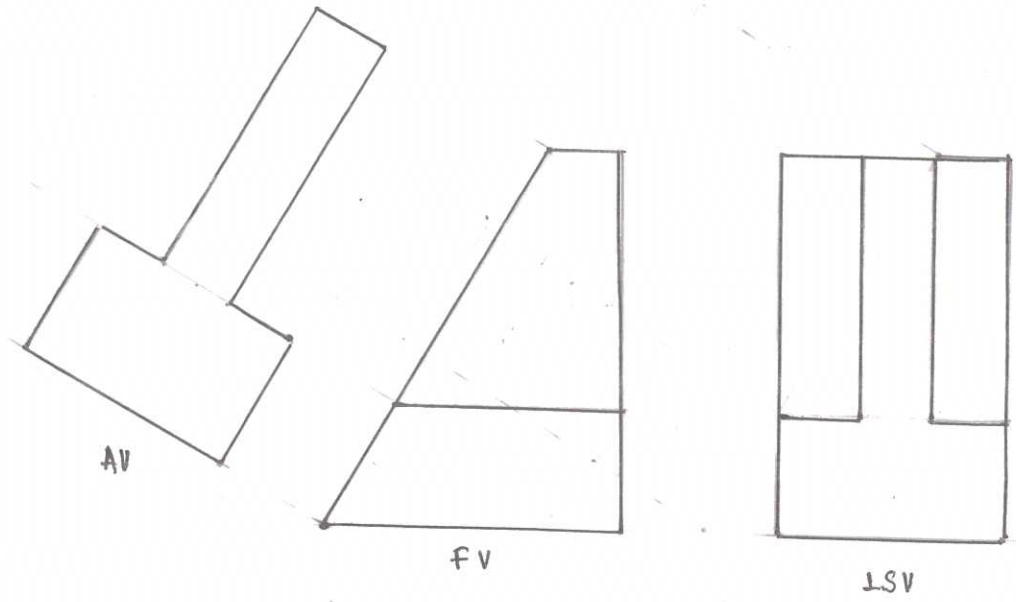

VIII

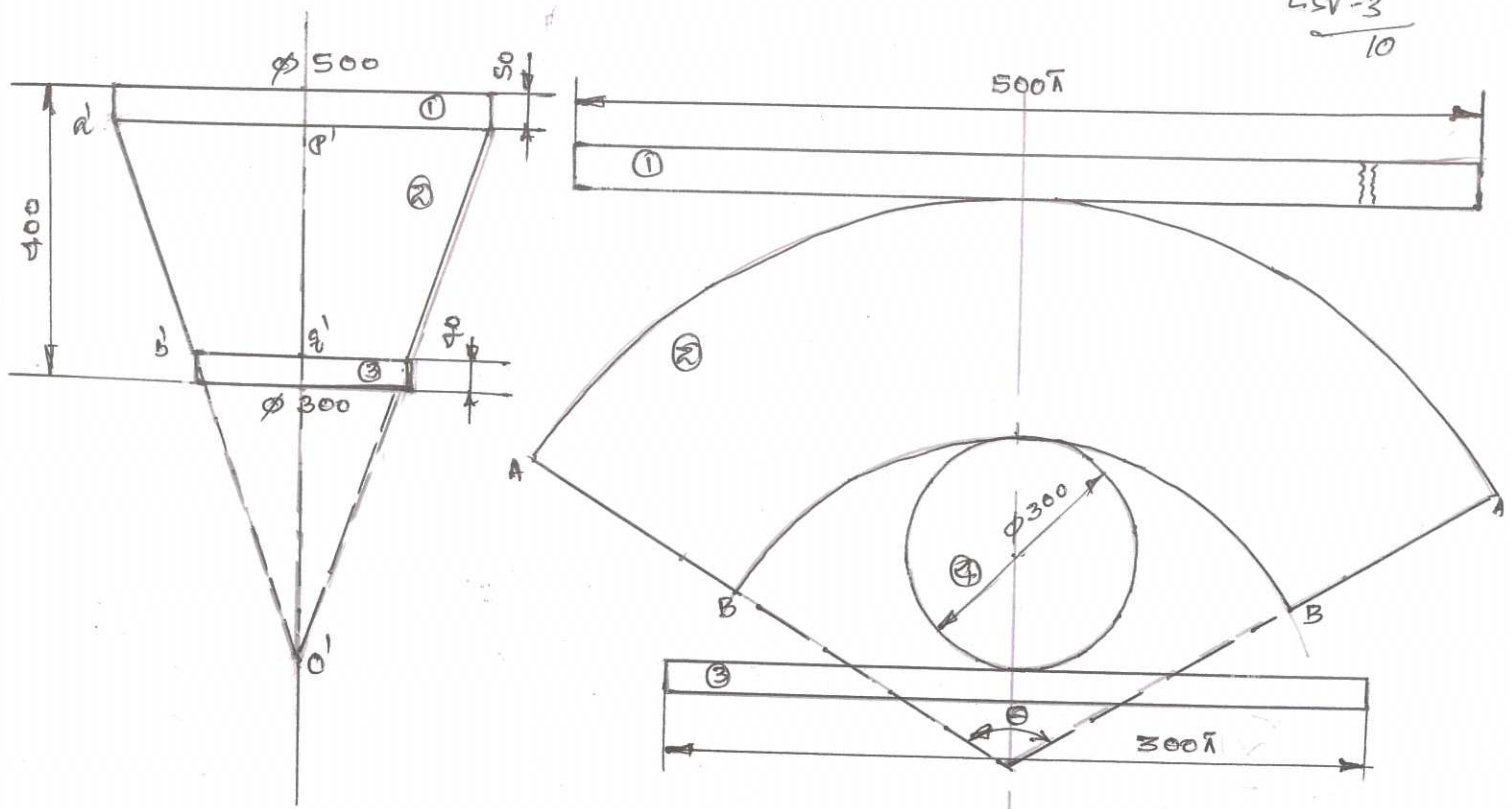

AV-4
 FV-3
 LSV-3
 10

$$\theta = \frac{d/P'}{r/O'} \times 360$$

$5 \times 2 = 10$

1x

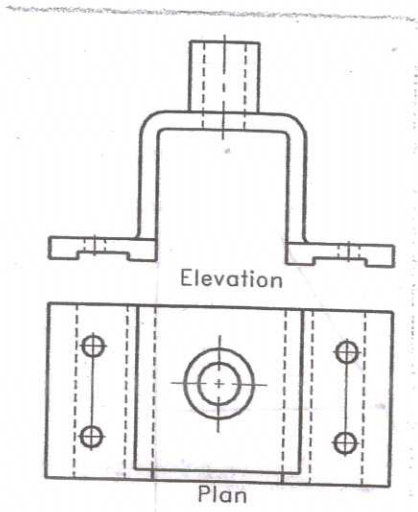

10 +
10
20

1x

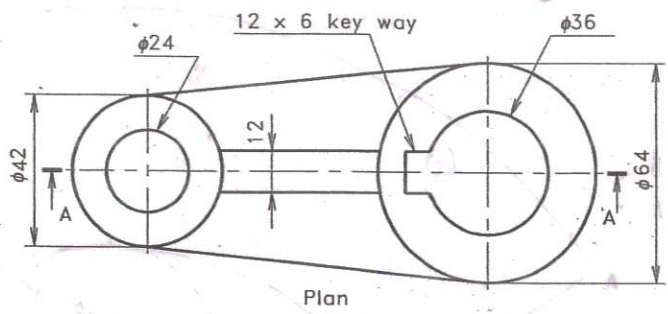
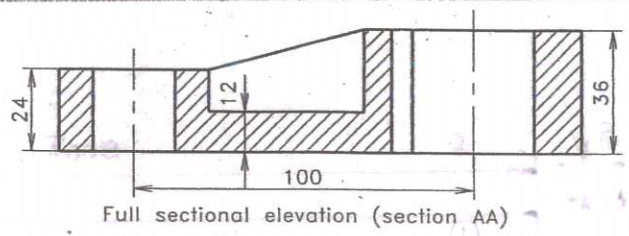

12 +
8
20

1x

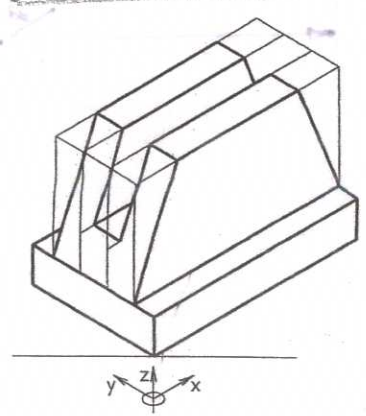

20