

**DIPLOMA EXAMINATION IN ENGINEERING/TECHNOLOGY/
MANAGEMENT/COMMERCIAL PRACTICE, NOVEMBER – 2020**

THEORY OF STRUCTURES I

[Maximum Marks: 75]

[Time: 2.15 Hours]

PART-A

(Answer *any three* questions in one or two sentences. Each question carries 2 marks)

- I. 1. State the principle of moments.
2. State parallel axis theorem.
3. Define Poisson's ratio.
4. Define circumferential stress in thin cylinders.
5. Write down the equation for simple bending of a beam. (3 x 2 = 6)

PART-B

(Answer *any four* of the following questions. Each question carries 6 marks)

- II 1. Explain any three systems of forces with neat sketch.
2. Briefly explain any four mechanical properties of metal.
3. State the relationship between elastic constants.
4. A cantilever beam AB, 2m long carries a point load of 3kN at its free end B. Draw shear force diagram and bending moment diagram.
5. A circular shaft 30mm diameter is subjected to torque of 6 kNm. Calculate the maximum shear stress developed in the shaft.
6. List the assumptions in the theory of simple bending.
7. A rectangular beam, 80mm wide and 150mm deep is subjected to shearing force of 30kN. Calculate the maximum shear stress and draw the distribution diagram for the shear stress. (4 x 6 = 24)

PART-C

(Answer *any of the three units* from the following. Each full question carries 15 marks)

UNIT – I

- III (a) Locate centre of gravity of cone and sphere. (6)

- (b) A compound beam is made by welding two steel plates 160mm x 12mm one on each flange of an ISLB 300 section as shown in figure. Find the moment of inertia of the beam section about an axis passing through its centre of gravity and parallel XX axis. Take moment of inertia of the ISLB 300 section about XX axis as $73.329 \times 10^6 \text{ mm}^4$. (9)

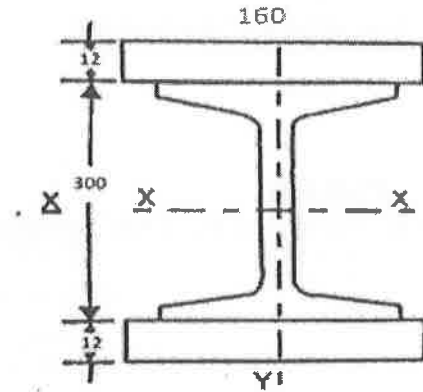

OR

- IV (a) Calculate the reactions at supports of a simply supported beam of length 6m. The beam carries a point load of 100kN at a distance of 2m from left support and also it carries a uniformly distributed load of 20kN/m over a length of 3m from the right end. (6)
- (b) Find moment of Inertia of T section with flange 150mm x 10mm and web also 150mm x 10mm about X-X and Y-Y axes passing through its centroid. (9)

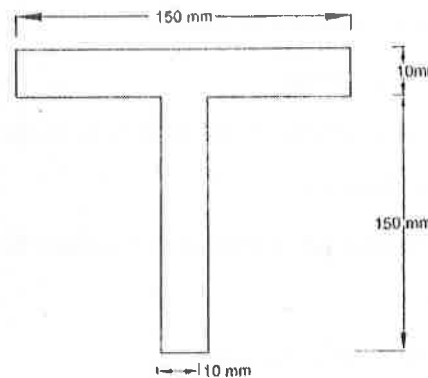

UNIT – II

- V (a) A concrete column of 350mm diameter is reinforced with 4 bars of 25mm diameter. Find the stress in steel when the concrete is subjected to stress of 4.5MPa. Find the safe load that the column can carry. Take $E_s/E_c = 18$. (6)
- (b) Sketch the stress strain diagram for mild steel and mark the important points. (9)

OR

- VI (a) An alloy bar 3m long is held between two supports. Find the stresses developed in the bar. When it is heated through 30K, if the both ends (i) do not yield (ii) yield by 1mm. Take E value of the alloy to be 120GPa and α as $24 \times 10^{-6}/K$. (6)

- (b) Determine the changes in length, breadth and thickness of a steel bar 4m long, 30mm wide and 20mm thick, when subjected to an axial pull of 120kN in the direction of its length. Take E as 200 GPa and Poisson's ratio as 0.30. (9)

UNIT- III

- VII (a) A solid circular steel shaft is required to transmit a torque of 50 kNm. Calculate the minimum diameter of the shaft, if the maximum shear stress is 80 MPa. (6)
- (b) A simply supported beam AB, 8m long carrying a point load 3kN at 2m from A and a point load 2kN at 3m from B. The beam is also carrying uniformly distributed load of 2kN/m over a length of 3m, situated between the point loads. Draw the SFD and BMD for the beam and determine the position and magnitude of maximum bending moment. (9)

OR

- VIII (a) Determine the circumferential and longitudinal stresses in the material of a thin cylindrical shell of 4m diameter and 10mm thick plates. The cylindrical shell is subjected to an internal fluid pressure of 1N/mm^2 . (6)
- (b) An overhanging beam ABC having length 4m and it carries a UDL of 4.5kN/m on the entire length. AB = 3m, BC = 1m. AB is simply supported, BC part of the beam is on the right side and is overhanging. Draw the SFD and BMD for the beam and find the position and value of maximum bending moment. Also find the point of contra flexure. (9)

UNIT - IV

- IX (a) A simply supported beam has a span of 5m and rectangular cross section 100mm x 200mm. Find the uniformly distributed load it can carry, if the maximum shear stress is not exceeds 0.7N/mm^2 . (6)
- (b) A beam of I section 300mm x 160mm has flanges 20mm thick and web 10mm thick. Calculate the maximum bending stress developed in I section for a bending moment of 30kNm. (9)

OR

- X (a) A rectangular beam 200mm deep and 300mm wide is simply supported over a span of 8m. Find the uniformly distributed load that the beam can carry, if bending stress is not exceed 120N/mm^2 . (6)
- (b) A rectangular beam 100mm wide and 300mm deep is subjected to a maximum shear force of 60kN. Determine (i) Average shear stress (ii) Maximum shear stress (iii) Shear stress at a distance of 30mm above the neutral axis. (9)