

DIPLOMA EXAMINATION IN ENGINEERING/TECHNOLOGY/  
MANAGEMENT/COMMERCIAL PRACTICE — OCTOBER, 2018

**QUANTITY SURVEYING - I**

[Time : 3 hours

(Maximum marks : 100)

PART — A

(Maximum marks : 10)

- [Note :—1. Missing data may be suitably assumed.  
2. Quantities should be worked out in standard form.  
3. Sketches on 4th page.]

Marks

I Answer *all* questions in one or two sentences. Each question carries 2 marks.

1. Define Estimate.
2. What is meant by Work Charged Establishment ?
3. Give the unit of measurement for (i) Earth filling in Plinth (ii) Pointing.
4. What is specification ?
5. What are the purposes of Rate Analysis ?

(5×2 = 10)

PART — B

(Maximum marks : 30)

II Answer any *five* of the following questions. Each question carries 6 marks.

1. Write down any six types of Estimate.
2. Define Abstract of Estimate.
3. What are the factors considered for fixing the rate per unit of an Item ?
4. What are the procedures of Estimating or method of Estimating ?
5. Define (a) Plinth area and (b) Carpet area
6. Write short notes on (a) Lump sum (b) Schedule of rates
7. Differentiate between Drawing and Specification.

(5×6 = 30)

## PART — C

(Maximum marks : 60)

(Answer *one* full question from each unit. Each full question carries 15 marks.)

## UNIT — I

- III (a) Briefly explain the methods of taking Quantities. 6
- (b) Calculate the area of the side slopes of portion of a bank for a length of 200 m, the heights of banks at the two ends being 2.50 m and 3.50 m and the ratio of the side slope 2:1. 5
- (c) If the side slopes are to be provided with 15 cm thick stone pitching, calculate the cost of pitching at the rate of Rs. 350/cu m. 4

OR

- IV (a) What is meant by Revised Estimate ? On what circumstances this type of estimate is required to be prepared ? 5
- (b) How is Detailed Estimate prepared ? 10

## UNIT — II

- V (a) From the given Figure - (2), Hexagonal room, Estimate the Quantity of Earthwork in foundation by Centre line method. 9
- (b) Estimate the quantities of Earthwork, Concrete and Brickwork of a simple step as shown in the figure (1). 6

OR

- VI Estimate from Figure - (2), the quantities of following items by centre line method.
- (i) Concrete in foundation
- (ii) Brickwork in foundation and plinth in 1:6 cement mortar.
- (iii) 2 cm Damp proof course. (3×5=15)

## UNIT — III

- VII Find out the quantities of Finishing 20 mm Cement plastered from the given Figure - (1), Simple Step in the standard format. 15

OR

- VIII (a) Calculate the quantity of cement concrete for cement concreting 1 km length of 3.70 m wide road for 8 cm thick layer. Also calculate cost at the rate of Rs. 375.00 per cu m. 4
- (b) Explain Centre line method for taking quantities of building plans. 5
- (c) Explain (i) Lead and (ii) Lift. 6

IX Work out the rate of standard unit for brick work in CM 1:5.

*Materials*

500 Nos.	Bricks	@ Rs. 3500/1000 Nos.
43 kg.	Cement	@ Rs. 350/bag
0.24cu m	Dry sand	@ Rs. 2500/cu m

*Labour*

0.7	Brick Mason	@ Rs. 750/Each/day
0.35	Man	@ Rs. 600/Each/day
1.20	Woman	@ Rs. 500/Each/day

*Conveyance charge of materials*

<i>Materials</i>	<i>Distance in km</i>	<i>Rate per km</i>
Cement	15	50
Sand	27	15
Brick	20	20

15

OR

X Work out the rate per cubic meter of Ashlar Masonry in Superstructure in 1:6 Cement Sand Mortar. Take - 10 cu.m.

*Materials*

12.5 cu m	Stone (undressed)	@ Rs. 2500/cu m
0.35 cu m	Cement (10 ½ bags)	@ Rs. 3970/cu m
2.10 cu m	Sand (local)	@ Rs. 2000/ cu m

*Labour*

½ No.	Mistri (Head Mason)	@ Rs.950/day
28 Nos.	Mason including cutter	@ Rs. 850/day
20 Nos.	Mazdoor(Beldar)	@ Rs. 700/day
20 Nos.	Boy or Women Coolie	@ Rs. 650/day
1½ Nos.	Bhishti	@ Rs.500/day
LS	Scaffolding	@ Rs. 250 LS
LS	Sundries, T&P etc.	@ Rs. 100 LS

15

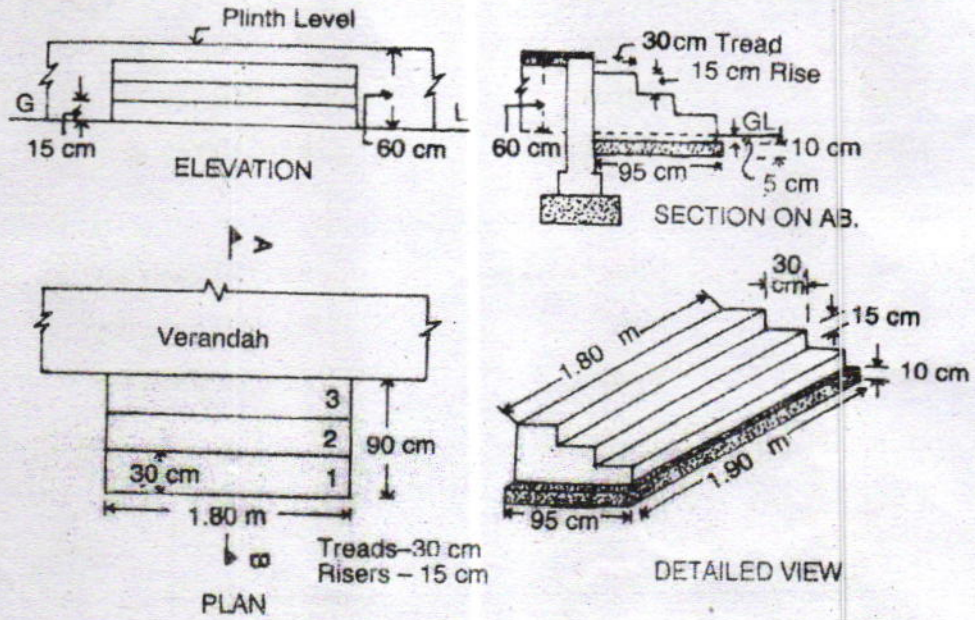

FIGURE:- (1) SIMPLE STEP

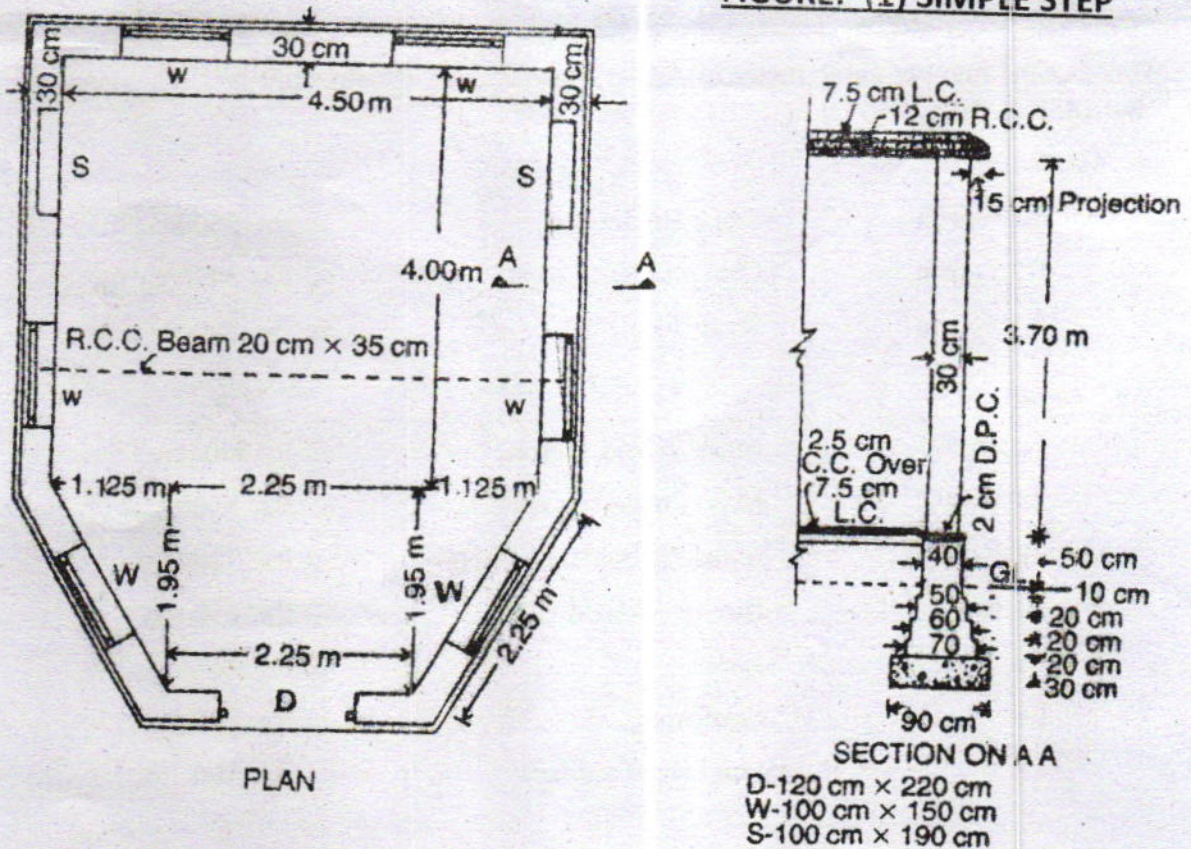

FIGURE (2):- HEXAGONAL ROOM