

Scheme of Valuation

Part A

- I (a) 1. It is the upper surface of the zone of saturation in the unconfined aquifer. In other words it is the free surface of ground water reservoir.
2. Alum, Chlorinated Copperas, Sodium aluminate, Ferrous Sulphate and Lime, Magnesium Carbonate, Polyelectrolytes. **(Any four)**
3. These are masonry or RCC chambers constructed on sewer lines for providing access to men so that they can attend to inspection, cleaning and maintenance of sewers.
4. It includes all kinds of dry waste of the community ie street and house sweepings garbage, ash etc.
5. Skimming tank is a chamber in which the floating substances like oil, fat, grease etc is separated and removed. **(5x2=10)**

Part B

II. (1) Seasonal variation:

The maximum consumption occurs during summer and is about 130% of the average consumption. These fluctuations may also be caused due to variation in use of water by industries in different seasons.

(2) Daily variation: This reflects house hold and industrial activities and depends on the habits of people, climatic condition of the day and nature of industrial and commercial activity. The consumption may be more on Sundays and holidays. Maximum daily consumption is about 180% of the average daily consumption.

(3) Hourly variation: The demand is small during 0 to 6 AM and increases sharply to the peak value between 8 to 10AM, then decreases about 1 PM, remains constant upto 4PM, again increases in the evening reaching another peak between 6 to 9PM and finally Falling to a low value in the late hours of night. Maximum hourly variation is usually taken as 150% of the average demand. **(3x2=6)**

(2) 1. A surface stream: The samples should be collected at a depth of 50 cm below the water surface so as to avoid floating impurities.

2. A tap or faucet: Sufficient amount of water should be allowed to waste and then mouth of tap or faucet is flamed for about two minutes. Afterwards some more water is wasted and then samples are collected.

3. A pump fitted to ground water source: Sufficient quantity of water should be pumped out before collecting samples. **(3x2=6)**

(3) 1. To remove the residual suspended and colloidal particles in water

2. To remove bacterial pollution

3. To change the undesirable chemical characteristics of water

4. To remove colour, odour and taste.

5. To remove iron and manganese from water.

(4) When a coagulant is thoroughly mixed in the water, it reacts with certain impurities in water, resulting in the formation of insoluble, gelatinous and flocculent, precipitate called "floc". This gelatinous floc enmeshes very fine and colloidal particles. Further the ions of floc having positive charge, attract the negatively charged colloids and bind them together. Thus, the whole process results in the formation of bigger and heavier flocs, which settle down. Thus, most of the fine colloidal particles and to some extent bacteria are eliminated by the process of sedimentation aided by coagulation.

(5) . Factors influencing selection of shape of sewer:

1. Efficiency of flow which depends on hydraulic mean depth.

2. Structural stability. 3. Cost of sewers 4. Ease of construction and maintenance

5. Resistance to internal and external pressures.

6. Maintenance of self-cleansing velocities even during minimum flow.

(6) **Cess pools:**

The cess pool consists of a pit or chamber lined with dry bricks or stone masonry with open joints, receiving excreta. The bottom is unlined and allows the liquid to percolate. Only solid matter remains in the cess pool, undergoing anaerobic digestion. The cess pool is periodically cleaned. This is an inferior method, as it produces obnoxious smell. The ground water is also polluted. The wells should not be located near these cess pools.

(7) **Advantages:**

1. Prevent foul gases from sewers
2. Prevent pathogenic organisms to enter into the building drainage system

Disadvantages:

1. Reduces the ventilation of sewers
2. Deeper water seal interferes with the smooth flow of sewage
3. Cleaning the trap is difficult.
4. Blocking of the house drain may occur due to improper placing of the plug, and also due to the pieces of cloth, brushes etc. getting into the drain and staying in the trap.

Part C

III (a)

Year	Population	Increase in Population	Percentage Increases in Population	Incremental Increase
1900	21610	—	—	—
1910	28560	6950	$\frac{6950 \times 100}{21610} = 32.16$	—
1920	37640	9080	$\frac{9080 \times 100}{28560} = 31.79$	+ 2130
1930	46520	8880	$\frac{8880 \times 100}{37640} = 23.59$	- 200
1940	55460	8940	$\frac{8940 \times 100}{46520} = 19.22$	+ 60
1950	63710	8250	$\frac{8250 \times 100}{55460} = 14.88$	- 690
1960	71320	7610	$\frac{7610 \times 100}{63710} = 11.94$	- 640
1970	79540	8220	$\frac{8220 \times 100}{71320} = 11.53$	+ 610
Average	Total	57930	145.11	+ 1270
per Decade		8276	$\frac{145.11}{7} = 20.73$	$\frac{+1270}{6} = +212$

Geometrical increase method:

$$P_n = P (1 + r/100)^n$$

Expected population in the year 1980 = $79540(1+20.73/100)^1 = 96,029$

Expected population in the year 1990 = $79540(1+ 20.73/100)^2 = 1,15,936$

Expected population in the year 2000 = $79540(1+ 20.73/100)^3 = 1,39,969$

Incremental increase method:

Expected population in the year 1990 = $79540 + (8276 + 212) \times 1 = 88, 028$

Expected population in the year 1990 = $79540 + (8276 + 212) \times 2 = 96, 516$

Expected population in the year 2000 = $79540 + (8276 + 212) \times 3 = 1, 05. 004$

(4+4=8)

III (b) Sunk wells: When soils are loose and cannot withstand open excavation, wells are constructed by this method. A well curb with cutting edge made up of RCC is placed on the ground. Masonry or hollow concreted blocks in mortar is constructed to some height on the curb. In place of masonry, RCC rings can also be placed. Then the earth within the curb is scooped out by hand tools and thrown out, thus sinking the RCC rings or masonry slowly. This method of placing rings, excavation and sinking is continued until the required depth is reached.

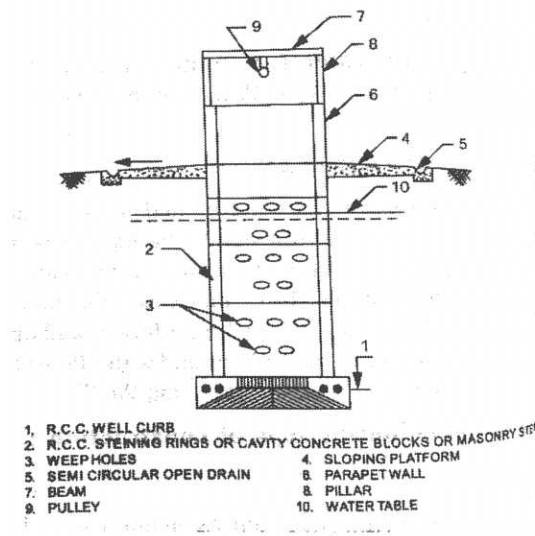

(4+3=7)

IV (a) Infiltration Galleries:

Infiltration galleries are the horizontal tunnel like wells constructed in open cut 3 to 4m deep along the banks or in the bed of rivers. The galleries are covered with masonry arches of RCC slabs. The side walls are provided with number of weep holes. The spaces between sides of the trench and wells are filled with graded gravel and pebble stones to increase the intake capacity. The floor is provided with longitudinal slope. Water is collected in the sump constructed at the end and pumped out.

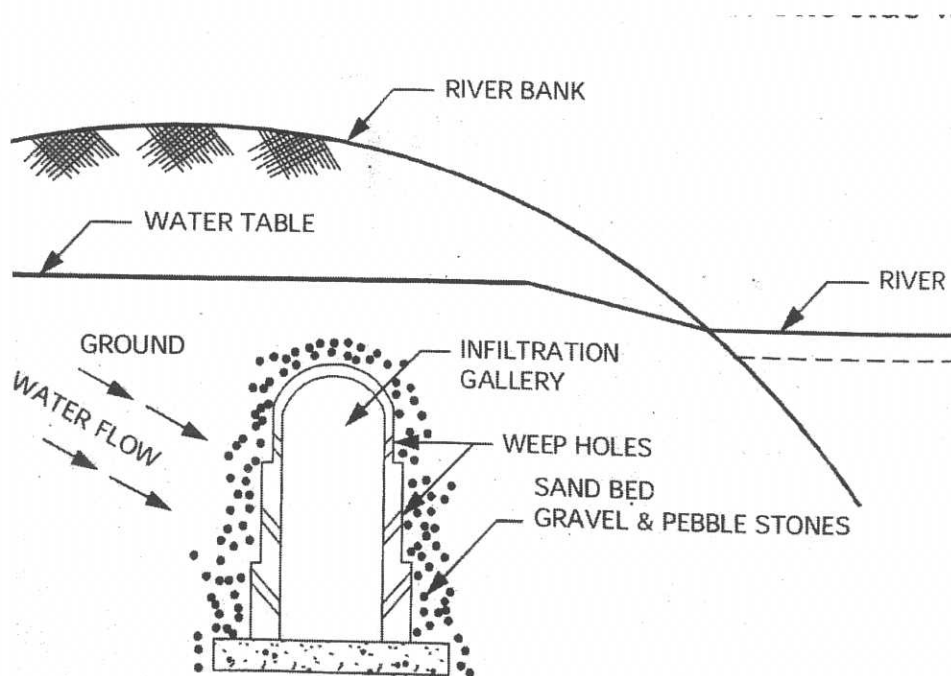

(4 +4=8)

IV (b) **Drilled wells:** The wells are drilled either by percussion or core or rotary drilling. A casing pipe is driven into the hole. The diameter varies from 0.15m to 1.0m and depth 100 to 300m. Strainers are introduced at all places where aquifers are intercepted. Development is done by any one of the methods like back washing, surging, or by compressed air. A gravel pack is provided around the strainer. The yield of these wells is high and hence dependable for water supply schemes.

(7)

5

V

(a) Requirements of a good disinfectant:

1. Able to kill pathogens in water
2. Should be cheap and easily available.
3. It should be reliable
4. It should not be toxic or harmful to consumers
5. It should not impart objectionable taste and odour.
6. It should kill bacteria quickly.
7. It should be easy to store, transport and handle easily.
8. It should not require high skill for application.
9. Easy to determine its concentration in treated water.
10. It should have some residual effect.

(Any eight)

(b) Break point chlorination:

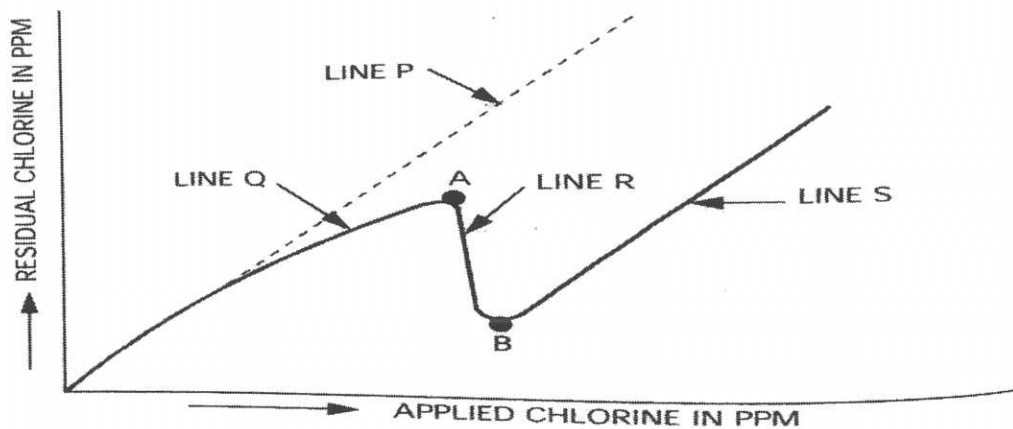

Break point chlorination is the addition of chlorine beyond “break point” from which onwards, any increase in dosage of chlorine, will simply appear as free residual chlorine.

If water is pure, any chlorine that is mixed in water will simply appear as residual chlorine and it is indicated by line P. when chlorine is added to water, some of it is consumed in killing bacteria and oxidising organic matter to form its compounds and the remaining chlorine is available as residual chlorine. This is indicated by line Q. The residual chlorine

rises up to point A and then suddenly drops to B. The fall of line R is due to the increased consumption of chlorine for oxidation of chloro-organic compounds and chloramines, indicated by bad odour and taste in water, Any further increase in chlorine dose beyond point B will appear as residual chlorine only and this is shown by line S. Beyond point B, suddenly odour and taste disappear due to the destruction of odour and taste producing compounds.

The principal advantage of break point chlorination is that it ensures free chlorine more effective than chloramines as a disinfectant. Also odour, taste and colour can be reduced by it. (3+4=7)

VI (a) Grid iron system:

In this system, the mains, submains and branches are interconnected with each other.

Advantages: 1. No dead ends, hence stagnation of water and its consequences eliminated. 2. in case of any break down or repair, water supply need not be stopped to that area, as it can be made available from another main or sub main. 3. In case of fire, large quantities of water can be drawn from all directions. 4. Water reaches from more than one route, frictional losses and size of pipe can be reduced.

Disadvantages: 1. More number of valves and longer length of pipes are required.

2. Overall cost is more 3. Design calculations are tedious

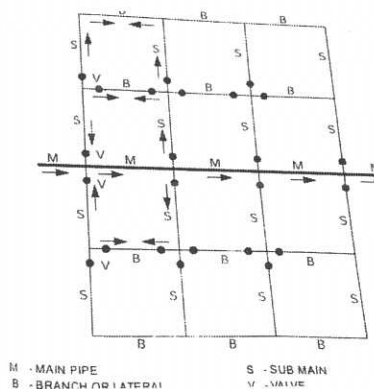

VI (b)

VI (b)

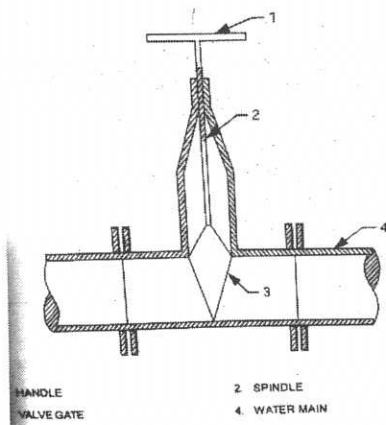

It is also called “gate valve”. It controls the flow of water through pipes. Valves are fixed at every 3 to 5 km intervals. By closing two valves at two ends, any section can be repaired. These are located at points of low pressure. Valve is made up of cast iron with stainless steel, brass or bronze mountings. By rotating the spindle the flow can be regulated.

(3+4=7)

VII (a)

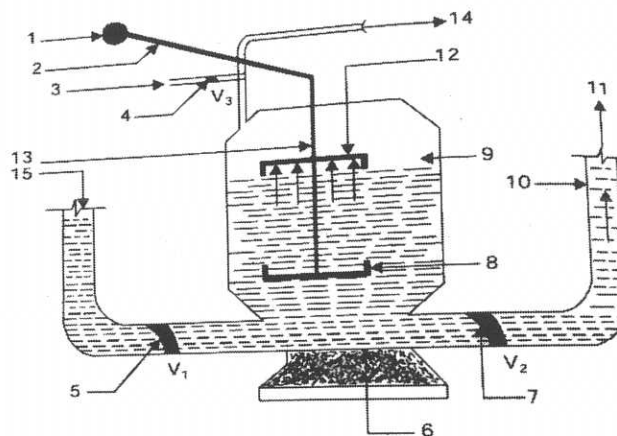

- | | |
|-------------------------------|-------------------------------|
| 1. COUNTER WEIGHT | 2. LEVER ARM |
| 3. COMPRESSED AIR INLET | 4. COMPRESSED AIR INLET VALVE |
| 5. ENTRANCE CHECK VALVE V_1 | 6. SEAT |
| 7. OUTLET CHECK VALVE V_2 | 8. LOWER CUP |
| 9. CAST IRON CHAMBER | 10. RISING ARM |
| 11. OUTLET | 12. UPPER CUP |
| 13. SPINDLE | 14. TO EXHAUST |
| 15. INLET | |

This is a typical type of pneumatic or air ejector. It consists of a cast iron chamber with a spindle having an upper and lower cup as shown in figure. Two valves V1 and V2 are provided at entrance and exit. A lever arrangement with a counter weight is provided so as 0.15N/mm^2 is supplied through V3. When sewage enters and rises in the vessel, air gets entrapped in the upper end and gets compressed. This pushes up the spindle, opening the valve V3. Compressed air rushes inside the chamber and forces the sewage out through the delivery pipe. After this, spindle is brought down by the weight of lower cup and closing V3. Pumping is now stopped and the sewage enters the chamber. Another cycle of operation is repeated and thus sewage is pumped. (4+4=8)

(b) Cast iron sewers:

These are used where high internal pressures and external loads are to be taken by the sewer. Cast iron is the most impure form of iron which contains highest proportion of carbon varying from 2 to 4.5%. It is manufactured by re melting pig iron with coke and lime stone in cupola furnace. The ultimate compressive strength is 600 N/mm^2 and ultimate Tensile strength is 150N/mm^2 . The C.I pipes ranging from 150 to 750 mm in dia. The pipes are manufactured by sand moulding or centrifugal casting. To protect from corrosion, they are treated with angus Smith process or cement mortar lining. (7)

VIII (a) Merits:

1. Sewers are smaller and hence economical
2. Quantity of sewage to be treated is smaller and hence cost of treatment is less.
3. There is no risk of pollution due to overflowing of storm water from sewers.
4. The quantity of sewage to be pumped if necessary is small. Hence, cost of pumping is low.

Demerits:

1. Due to small discharge in sewers the self-cleansing velocity is not maintained and hence the possibility of silting.
2. Maintenance cost of two sets of sewers is more.
3. Greater obstruction to traffic during repairs.
4. Plumping is not simple.

(8)

(b)

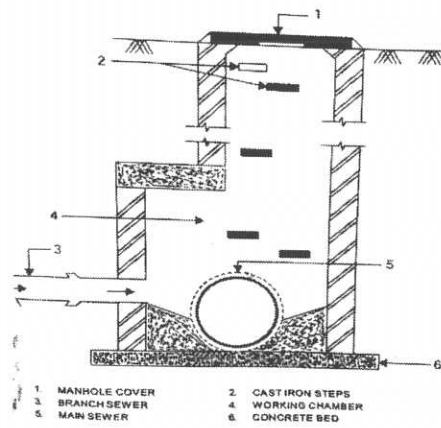

It consists of three components namely

Man hole cover, Access shaft, Working chamber.

Man hole is a concrete cover or masonry structure so as to have a working chamber with sufficient space for a man to stand inside and carry out work. The chamber is either circular or rectangular in plan. The access shaft provides an access to the working chamber. A series of steps are provided to facilitate descending in to the working chamber. The opening is covered with a man hole cover made of cast iron. The concrete floor of chamber slopes 1 in 6 towards the centre so that sewage from inlet sewers flows into semi circular channel and further into the outlet sewer.

(4+4=8)

IX (a) Advantages of Bio – gas plants:

1. Unstable and putrescible organic solids are reduced into stable, acceptable form
2. The digested sludge coming out of plants has no bad odour. Hence, disposal become easy
3. There is energy generation which can be used for cooking, lighting etc.
4. There is almost nutrient conservation during digestion and hence the digested sludge act as a good manure.
5. Ground water pollution is prevented.
6. Aesthetic value
7. The pathogenic organisms are destroyed during digestion
8. House fly and mosquito breeding is eliminated
9. Destruction of weed seeds present in the dung.

(Any eight)

(b) Advantages:

1. High efficiency in the removal of BOD and solids by about 90%
2. Free from fly nuisance and bad smell
3. Area required for construction is small
4. Initial cost is less
5. Loss of head in the process is small

Disadvantages:

1. Its operational cost is high
2. Skilled supervision is necessary
3. The change in quality and quantity of effluent upsets the process
4. Large volume of sludge is produced.

(Any seven)

//

X (a) Requirements of a good drainage systems in a building:

1. The foul matter should be quickly removed away from the sanitary fixtures.
2. To prevent the entry of gases, vermin etc. from the sewers into the buildings.
3. Drainage pipe should be strong and durable.
4. Pipe and joints should be air tight to prevent any leakage of waste water or gases.
5. It should have sufficient accessibility for inspection, cleaning and removing obstruction
6. It should not give scope for air locks, obstructions etc
7. Pipe should be non-absorbent material.
8. Branch drain should be as short as possible.
9. As far as possible drains should not pass under buildings.
10. The system should have traps at all necessary points.

(Any seven)

(b) Bore- hole latrine:

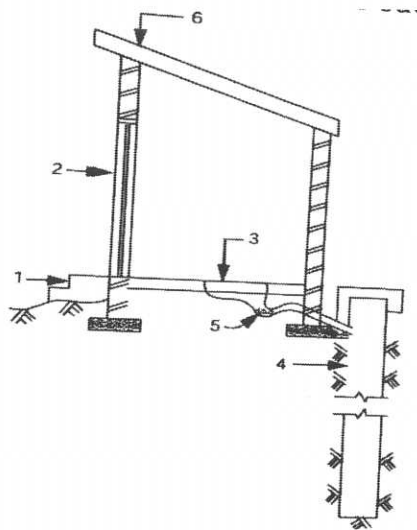

STEPS
SEAT
WATER SEAL

2 DOOR
4 BORE HOLE
6 ROOF

The bore hole is made with an auger. The size of hole is 200 to 300mm dia, and 4 to 8m deep. The bottom of the bore – hole should be 1 to 2m above the highest water table in the locality. Otherwise, it may pollute the ground water. When the hole is completely filled up the top is covered with a thick layer of soil and another hole is dug by the side of it. The old hole may be re bored after 6 months or so when the matter is completely digested by anaerobic bacteria. This method is suitable for the regions where sandy soils are available.

The nuisance of bad odour may be avoided by providing a water seal trap. **(3+4=7)**