

TED (15)2005B
(Revision-2015)

A20-00230

Reg.No.....

Signature.....

DIPLOMA EXAMINATION IN ENGINEERING/TECHNOLOGY/
MANAGEMENT/COMMERCIAL PRACTICE - APRIL-2020

ENGINEERING GRAPHICS

[Maximum marks: 75]

(Time: 2.15 hours)

- [Note:- 1. Missing data if any suitably assumed.
2. Sketches to be accompanied.]**

PART – A

I. Answer **any three** questions in one or two sentences. Each question carries 2 marks.

1. List any four drawing instruments for preparation of engineering drawing.
 - Drawing sheet.
 - Drawing board.
 - Mini drafter.
 - T square

2. Define helix.

The **helix** is a curve generated on the surface of the cylinder by a point which revolves uniformly

3. Mention the need of sectional views.

Sections are used to clarify the interior construction of a part that can not be clearly described by hidden lines in exterior views. By taking an imaginary cut through the object and removing a portion, the inside features may be seen more clearly.

4. What is cavalier oblique projection?

In cavalier projection (sometimes cavalier perspective or high view point) a point of the object is represented by three coordinates, x, y and z. On the drawing, it is represented by only two coordinates, x" and y". On the flat drawing, two axes, x and z on the figure, are perpendicular and the length on these axes are drawn with a 1:1 scale; it is thus similar to the dimetric projections, although it is not an axonometric projection, as the third axis, here y, is drawn in diagonal, making an arbitrary angle with the x" axis, usually 30 or 45°. The length of the third axis is not scaled

5. Write any four commonly used CAD packages.

- SolidWorks. ...
- Inventor. ...
- Revit. ...
- AutoCAD. ...
- Civil 3D. ...

(3 x 2 = 6)

PART – B

II. Answer any *four* of the following questions. Each question carries 11 marks.

1. Redraw the given figure 1 and dimensions as per BIS.

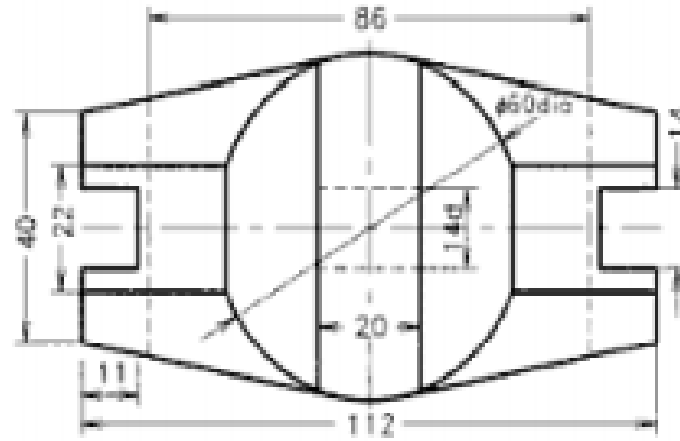

2. Construct an ellipse by concentric circle method whose major and minor axes are 100 mm and 60 mm respectively.

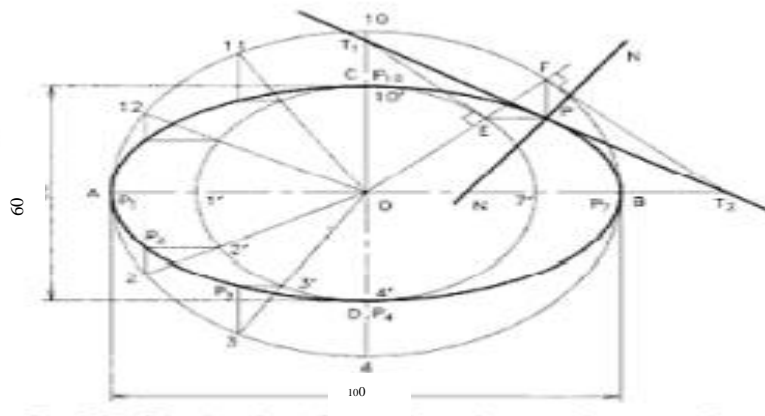

3. Draw the involute of a regular pentagon of 40mm side.

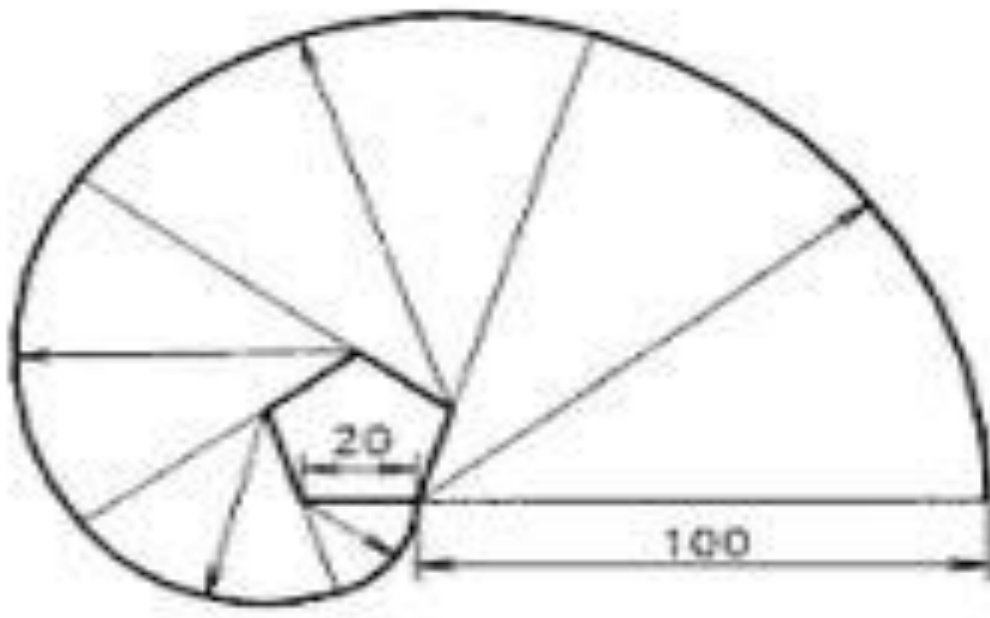

4. Draw the projections of following point in common reference line.

(i) Point A is 10mm above HP and 15mm in front of VP.

(ii) Point B is 25mm below HP and 15mm behind VP.

(iii) Point C is in HP and VP.

(iv) Point D is in HP and 18mm behind VP.

(v) Point E is 20mm below HP and 15mm in front of VP.

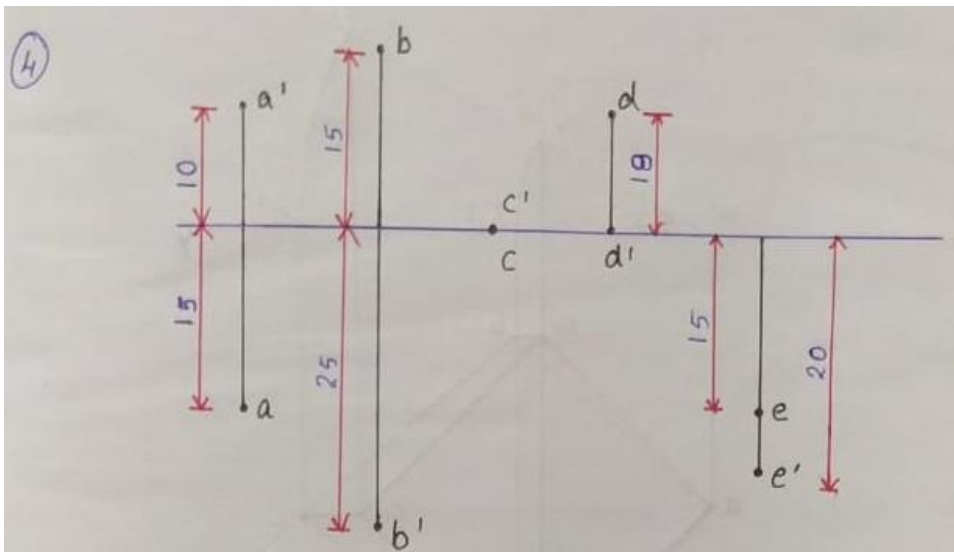

5. The front view of a 75mm long line measure 55mm. The line is parallel to HP and one of its end is in VP and 25mm below HP. Draw the projections of line and determine its inclination with VP.

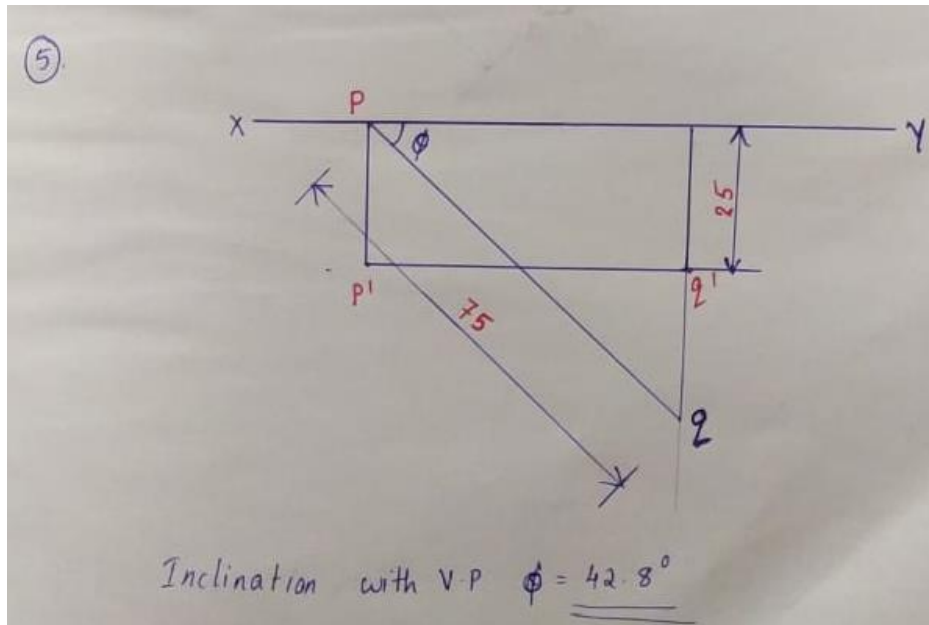

6. Draw the projection of square lamina ABCD of 60mm side resting on its corner A on HP when its diagonal AC is inclined 30° to HP and diagonal BD is perpendicular to VP.

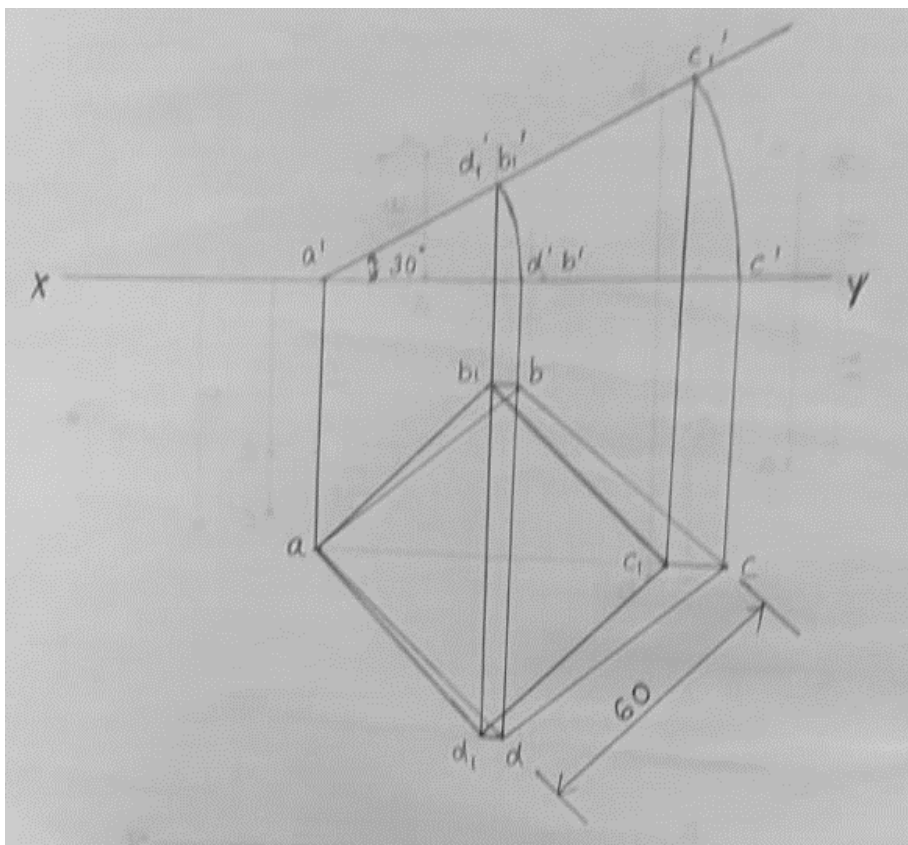

7. Draw the development of funnel shown in figure 2.

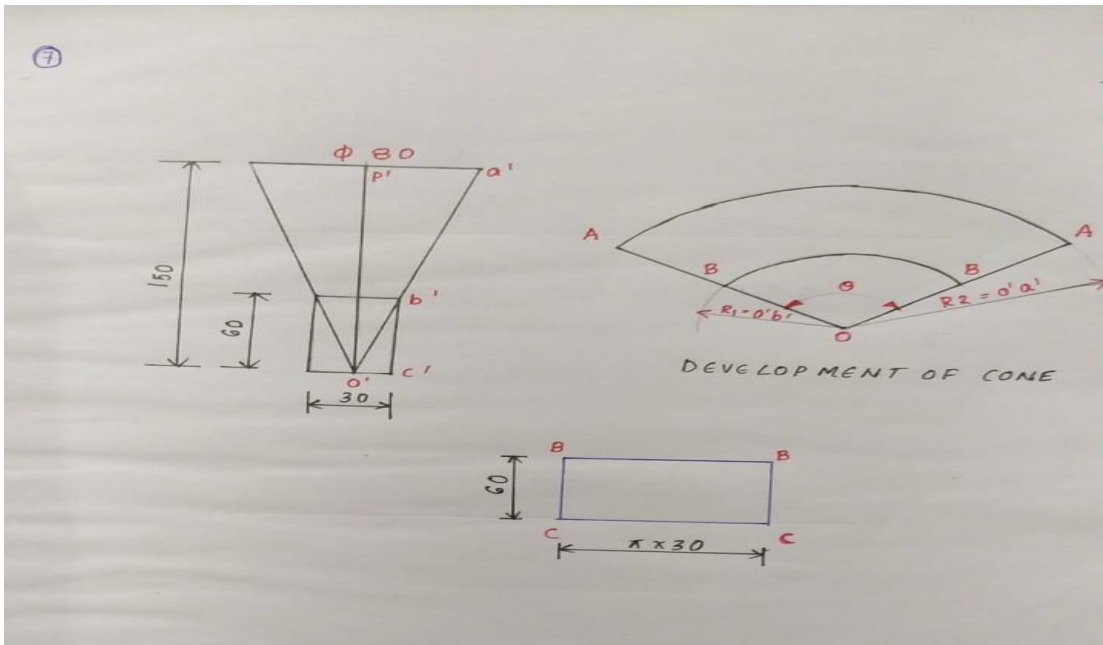

(4 x 11=44)

OR

2. The pictorial view of an object is shown in figure 4. Draw full sectional front view in the direction F and side view from right.

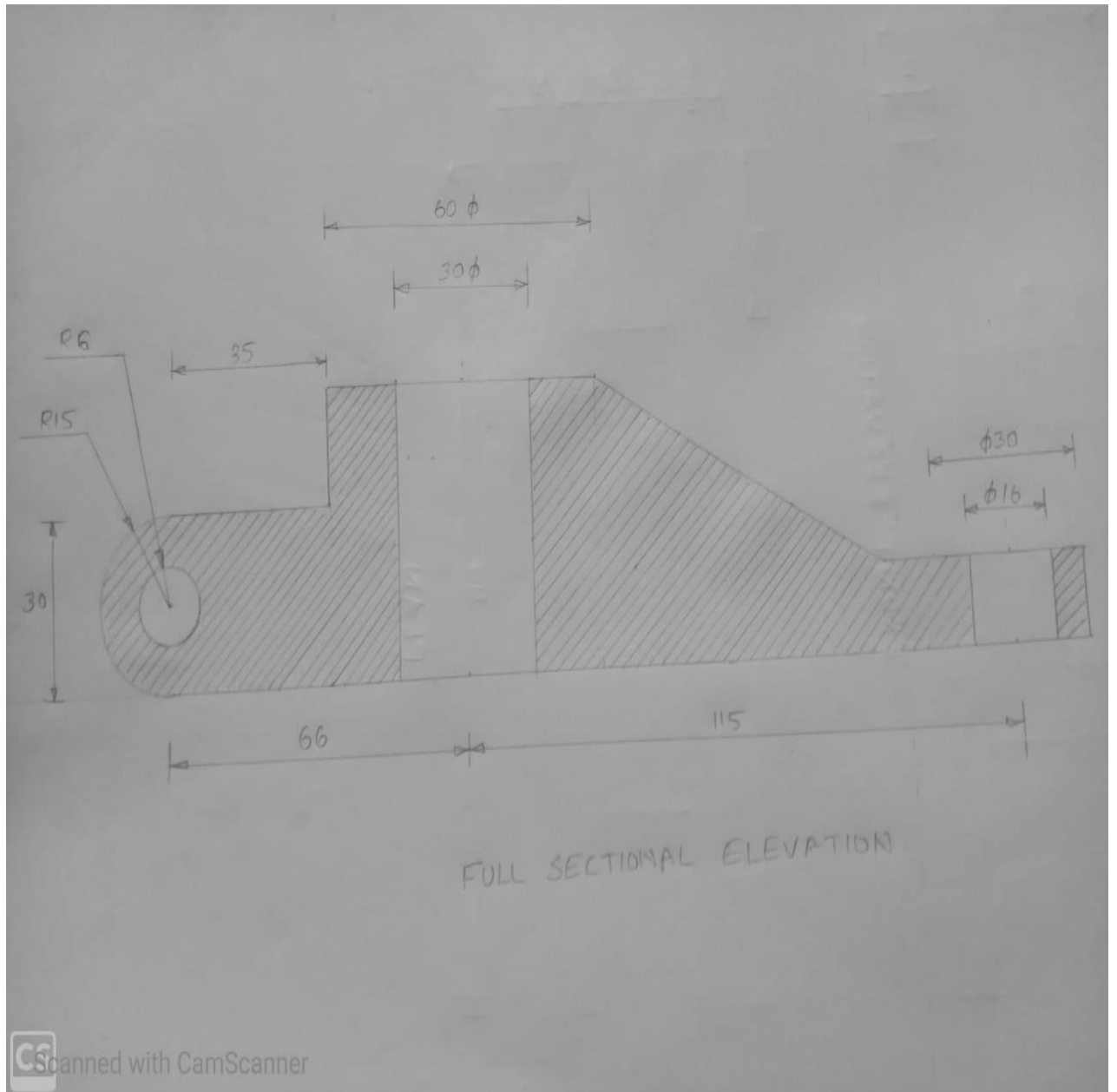

OR

3. The orthographic view of an object is shown in figure 5. Draw its isometric view.

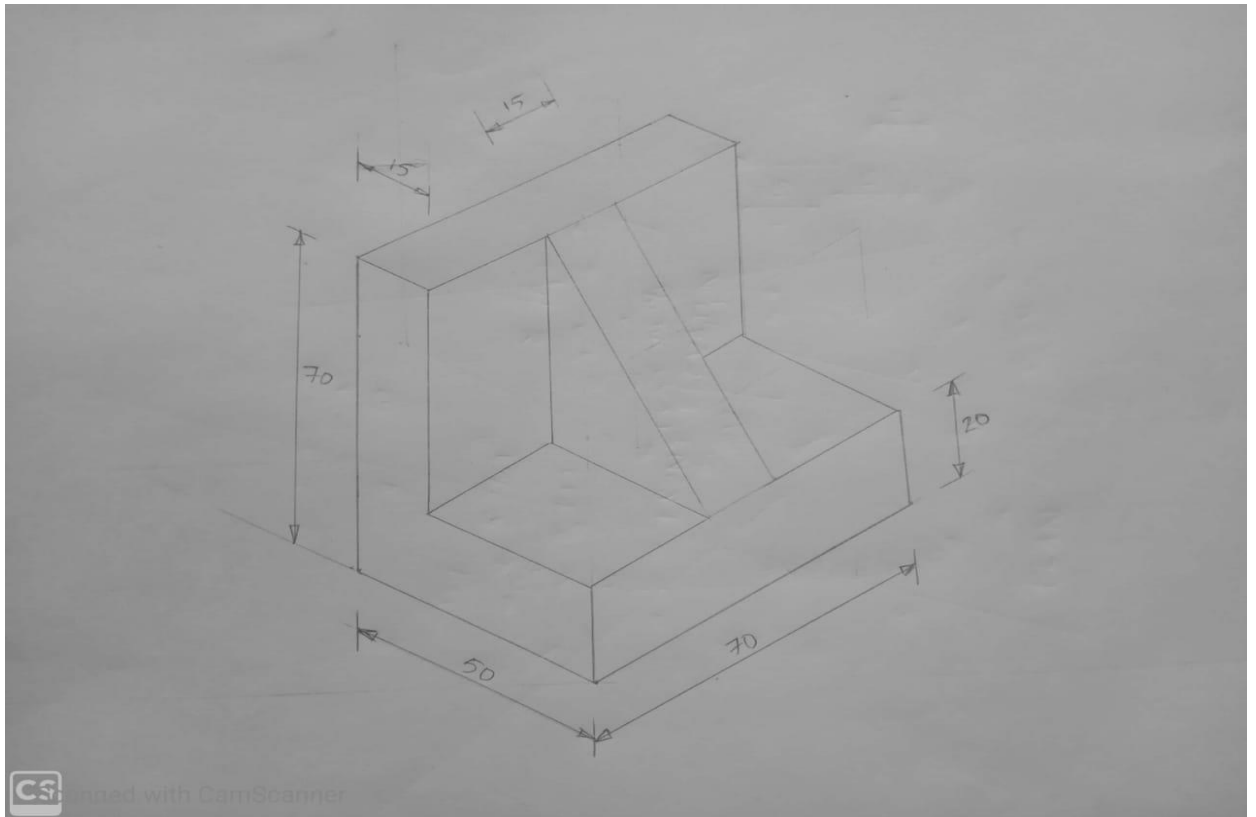

(1x25 =25)

